

**FLOOR-EQUIPMENT-PARTS.COM**

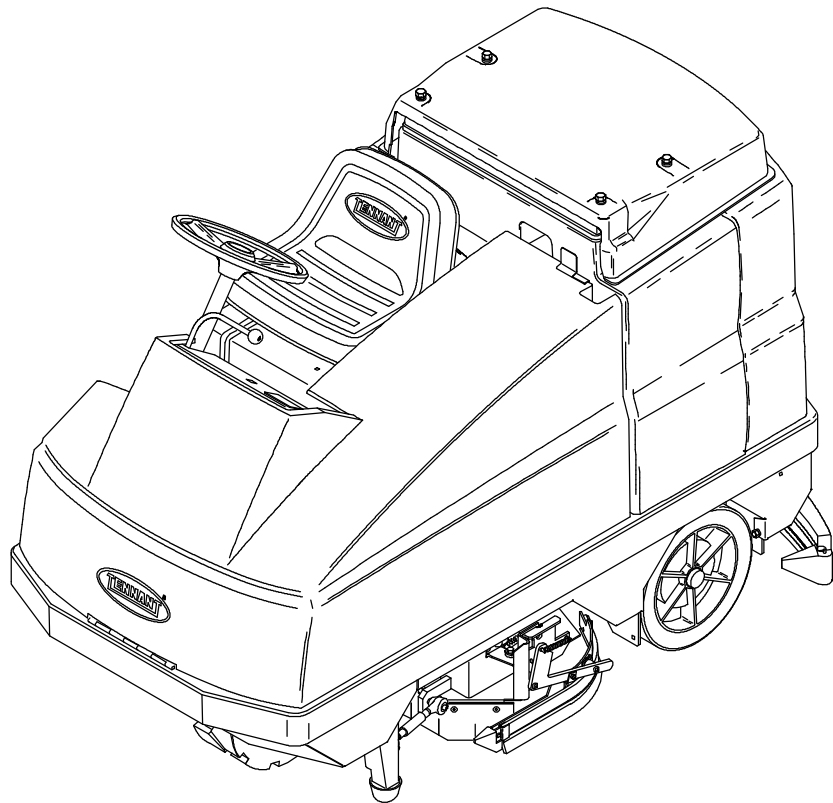

# 515

**Operator Manual**



**MM420**  
**Rev.09**



This manual is furnished with each new TENNANT Model 515. It provides necessary operating and preventive maintenance instructions. Read this manual completely and understand the machine before operating or servicing it.

This machine will provide excellent service. However, the best results will be obtained at minimum costs if:

- The machine is operated with reasonable care.
- The machine is maintained regularly – per the maintenance instructions provided.
- The machine is maintained with TENNANT supplied or equivalent parts.

Manual Number – MM420

Revision: 09

Published: 6-00

**CONTENTS**

	Page		Page
SAFETY PRECAUTIONS .....	3	MAINTENANCE .....	48
OPERATION .....	5	MAINTENANCE CHART .....	48
OPERATOR RESPONSIBILITY .....	5	LUBRICATION .....	50
MACHINE COMPONENTS .....	6	PROPELLING GEARBOX .....	50
SYMBOL DEFINITIONS .....	7	FRONT WHEEL SUPPORT	
CONTROLS AND INSTRUMENTS .....	8	BEARING .....	50
BRAKE PEDAL .....	9	STEERING UNIVERSAL JOINT .....	50
DIRECTIONAL PEDAL .....	9	SCRUB HEAD PARALLEL ARMS .....	51
STEERING WHEEL .....	10	REAR SQUEEGEE CASTER .....	52
SOLUTION LEVER .....	10	STEERING GEAR CHAIN .....	52
BATTERY DISCHARGE INDICATOR .....	11	BATTERIES .....	53
HOURMETER .....	11	CHARGING THE BATTERIES .....	54
CONTROL PANEL MESSAGE		CONTROL PANEL .....	56
DISPLAY .....	12	ELECTRIC MOTORS .....	57
CHANGING MESSAGE DISPLAY		PROPELLING CIRCUIT .....	57
LANGUAGE .....	13	SCRUB HEAD .....	57
RECOVERY TANK FULL INDICATOR .....	13	SCRUB HEAD FLOOR SKIRTS .....	58
ES™ SWITCH (OPTION) .....	14	SCRUB HEAD GAS SPRING .....	58
EDGE SCRUB SWITCH .....	14	SCRUB HEAD ADJUSTMENTS .....	58
REAR SQUEEGEE SWITCH .....	14	SCRUB BRUSHES .....	58
SCRUB SWITCH .....	15	REPLACING THE SCRUB BRUSHES .....	59
ON-OFF KEY SWITCH .....	16	SOLUTION SYSTEM .....	60
HORN BUTTON .....	16	SOLUTION VALVE .....	60
OPERATING LIGHTS SWITCH		RECOVERY TANK .....	60
(OPTION) .....	16	SOLUTION TANK .....	61
PARKING BRAKE .....	17	SQUEEGEES .....	62
POWER WAND SWITCH (OPTION) .....	17	REAR SQUEEGEE .....	62
CIRCUIT BREAKERS .....	18	LEVELING THE REAR	
SOLUTION TANK DRAIN HOSE .....	19	SQUEEGEE .....	62
RECOVERY TANK DRAIN HOSE .....	19	ADJUSTING REAR SQUEEGEE	
POSITIVE SOLUTION CONTROL		BLADE DEFLECTION .....	64
DRAIN (OPTION) .....	19	SIDE SQUEEGEE ADJUSTMENT .....	65
OPERATOR SEAT .....	19	SQUEEGEE BLADES .....	65
HOW THE MACHINE WORKS .....	20	REAR SQUEEGEE BLADES .....	65
PRE-OPERATION CHECKLIST .....	21	REPLACING OR ROTATING THE	
STARTING THE MACHINE .....	22	REAR SQUEEGEE BLADES .....	65
FILLING THE TANKS .....	22	SIDE SQUEEGEES BLADES .....	66
SCRUBBING AND BRUSH		REPLACING SIDE SQUEEGEE	
INFORMATION .....	25	BLADES .....	67
SCRUBBING .....	26	CHAINS .....	68
DOUBLE SCRUBBING .....	28	STEERING GEAR CHAIN .....	68
LOCKING UP SIDE SQUEEGEES .....	28	STATIC DRAG CHAIN .....	68
UNLOCKING SIDE SQUEEGEES .....	29	BRAKES AND TIRES .....	69
STOP SCRUBBING .....	30	BRAKES .....	69
DRAINING AND CLEANING THE		TIRES .....	69
TANKS .....	31	FRONT WHEEL .....	69
STOP THE MACHINE .....	34	PUSHING, TOWING, AND	
POST-OPERATION CHECKLIST .....	35	TRANSPORTING THE MACHINE .....	70
OPERATION ON INCLINES .....	36	PUSHING OR TOWING THE	
OPTIONS .....	37	MACHINE .....	70
VACUUM WAND .....	37	TRANSPORTING THE MACHINE .....	71
POWER WAND .....	41	MACHINE JACKING .....	73
MACHINE TROUBLESHOOTING .....	46	STORAGE INFORMATION .....	74

# CONTENTS

---

	Page
SPECIFICATIONS .....	75
GENERAL MACHINE PERFORMANCE ..	75
POWER TYPE .....	76
STEERING .....	76
BRAKING SYSTEM .....	76
TIRES .....	76
MACHINE DIMENSIONS .....	77
INDEX .....	78

## SAFETY PRECAUTIONS

The following symbols are used throughout this manual as indicated in their description:



**WARNING:** To warn of hazards or unsafe practices that could result in severe personal injury or death.

**FOR SAFETY:** To identify actions that must be followed for safe operation of equipment.

The following information signals potentially dangerous conditions to the operator or equipment. Read this manual carefully. Know when these conditions can exist. Locate all safety devices on the machine. Then, take necessary steps to train machine operating personnel. Report machine damage or faulty operation immediately. Do not use the machine if it is not in proper operating condition.

**FOR SAFETY:**

1. **Do not operate machine:**
  - Unless trained and authorized.
  - Unless operation manual is read and understood.
  - In flammable or explosive areas unless designed for use in those areas.
  - In areas with possible falling objects unless equipped with overhead guard.
2. **Before starting machine:**
  - Make sure all safety devices are in place and operate properly.
  - Check brakes and steering for proper operation.
3. **When starting machine:**
  - Keep foot on brake and directional pedal in neutral.
4. **When using machine:**
  - Use brakes to stop machine.
  - Go slow on inclines and slippery surfaces.
  - Use care when backing machine.
  - Do not carry riders on machine.
  - Always follow safety and traffic rules.
  - Report machine damage or faulty operation immediately.
  - Follow mixing and handling instructions on chemical containers.

5. **Before leaving or servicing machine:**
  - Stop on level surface.
  - Set parking brake.
  - Turn off machine and remove key.
6. **When servicing machine:**
  - Avoid moving parts. Do not wear loose jackets, shirts, or sleeves when working on machine.
  - Block machine tires before jacking machine up.
  - Jack machine up at designated locations only. Block machine up with jack stands.
  - Use hoist or jack of adequate capacity to lift machine.
  - Wear eye and ear protection when using pressurized air or water.
  - Disconnect battery connections before working on machine.
  - Avoid contact with battery acid.
  - Use Tennant supplied or equivalent replacement parts.
7. **When loading/unloading machine onto/off truck or trailer:**
  - Turn off machine.
  - Use winch. Do not drive the machine onto/off the truck or trailer unless the load height is 380 mm (15 in) or less from the ground.
  - Set parking brake after machine is loaded.
  - Block machine tires.
  - Tie machine down to truck or trailer.



**WARNING:** Batteries emit hydrogen gas. Explosion or fire can result. Keep sparks and open flame away. Keep covers open when charging.



**WARNING:** Flammable materials can cause an explosion or fire. Do not use flammable materials in tank(s).



**WARNING:** Flammable materials or reactive metals can cause an explosion or fire. Do not pickup.

# SAFETY PRECAUTIONS

The safety labels appear on the machine in the locations indicated. If these or any label becomes damaged or illegible, install a new label in its place.

**FOR SAFETY LABEL - LOCATED ON THE MOTOR COVER PANEL.**



**CLEANING SOLUTION LABEL - LOCATED ON THE TANKS COVER.**

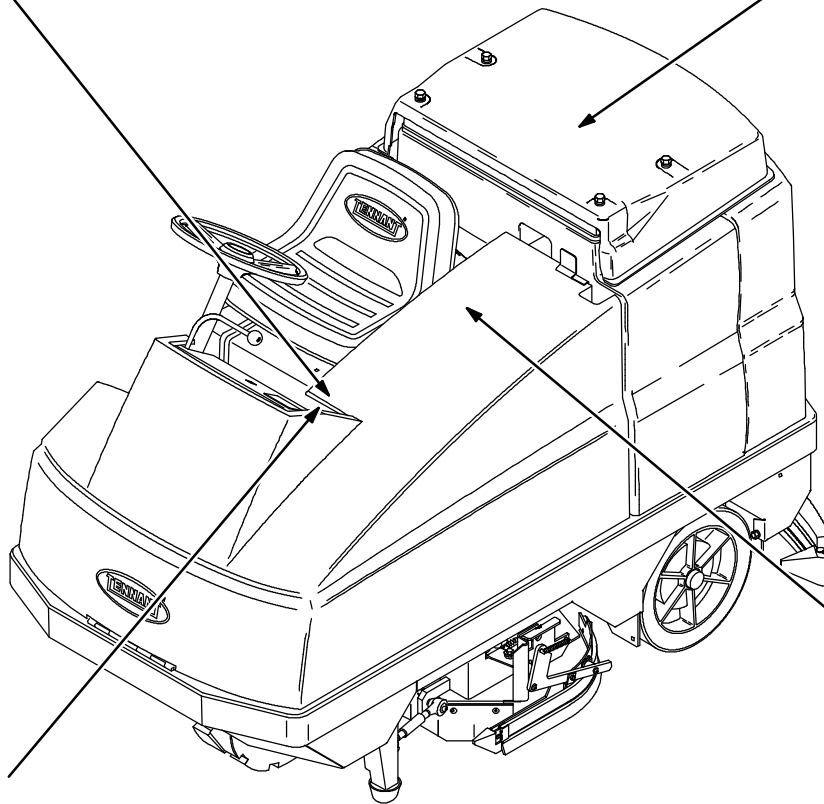
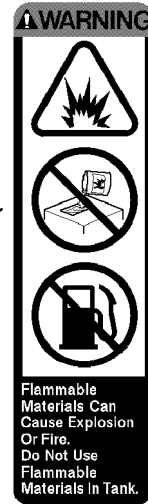

10390



**FLAMMABLE SPILLS LABEL - LOCATED ON THE MOTOR COVER PANEL.**



**BATTERY CHARGING LABEL - LOCATED ON THE LINTEL.**

## OPERATION

## OPERATOR RESPONSIBILITY

- The operator's responsibility is to take care of the daily maintenance and checkups of the machine to keep it in good working condition. The operator must inform the service mechanic or supervisor when the maintenance intervals are required as stated in the *MAINTENANCE* section of this manual.
- Read this manual carefully before operating this machine.

**FOR SAFETY: Do not operate machine, unless operation manual is read and understood.**

- Check the machine for shipping damage. Check to make sure the machine is complete per shipping instructions.
- Keep your machine regularly maintained by following the maintenance information in this manual. We recommend taking advantage of a regularly scheduled service contract from your Tennant representative.
- Order parts and supplies directly from your authorized Tennant representative. Use the parts manual provided when ordering parts.
- After the first 50 hours of operation, follow the recommended procedures stated in the *MAINTENANCE CHART*.

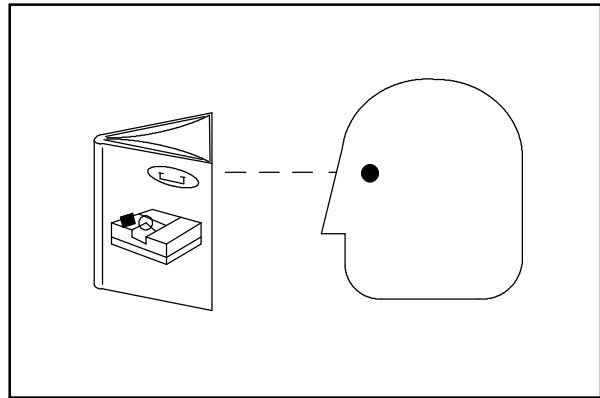

07324

## MACHINE COMPONENTS

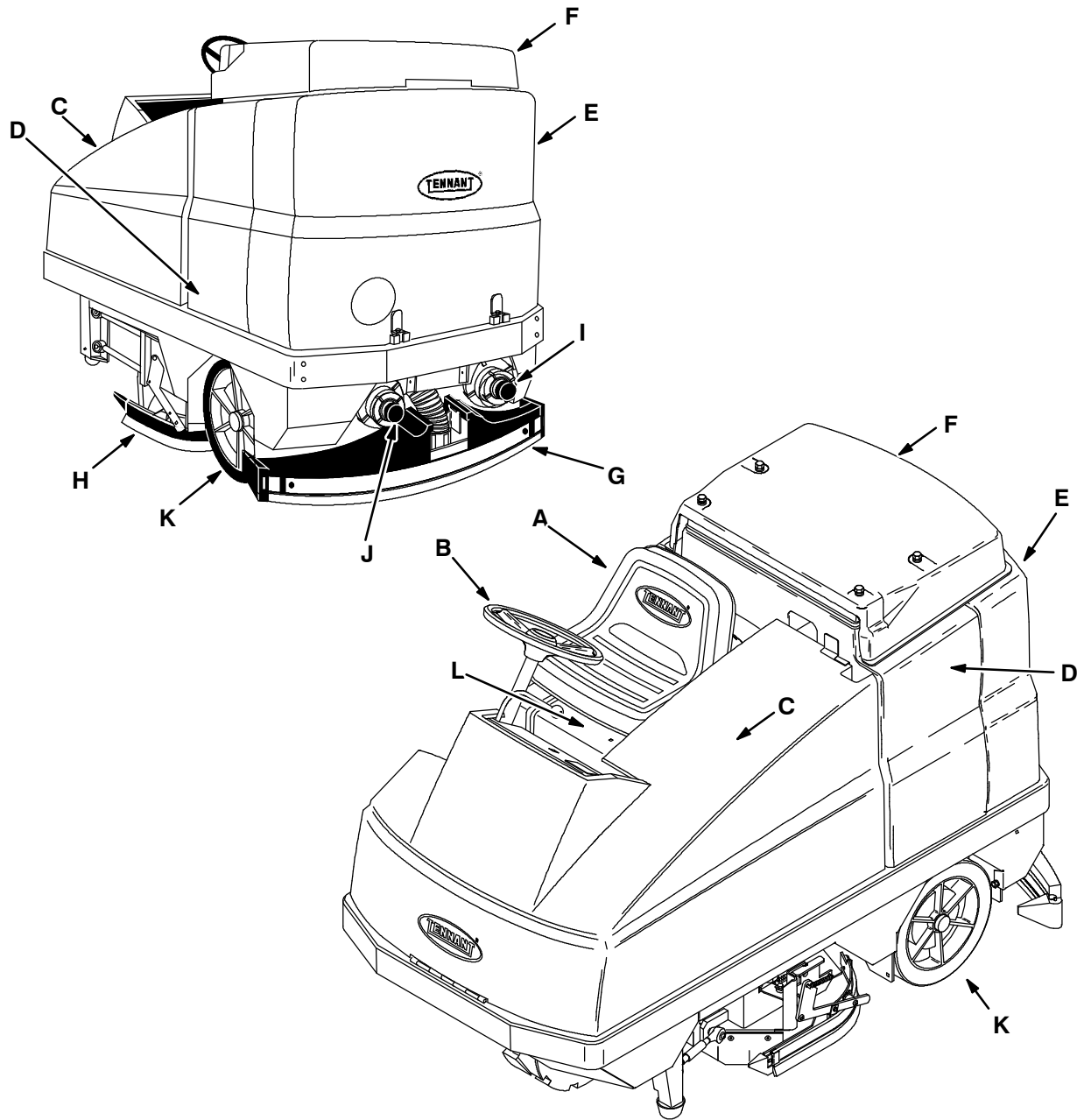

- A. Operator seat
- B. Steering wheel
- C. Machine cover
- D. Recovery tank
- E. Solution tank
- F. Tank cover
- G. Rear squeegee
- H. Side squeegee
- I. Solution tank drain
- J. Recovery tank drain
- K. Rear wheel
- L. Seat support

10641  
10390



**SYMBOL DEFINITIONS**

These symbols identify controls, displays, and features on the machine:

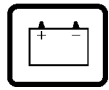

Battery charging system



Headlights



Hour meter

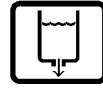

Solution flow



Recovery tank full

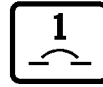

Circuit breaker #1



ES™



Circuit breaker #2



Scrub brush edge clean



Circuit breaker #3



Squeegee down



Circuit breaker #4



Down pressure



Circuit breaker #5



Scrub brush down and on



Circuit breaker #6



Horn



Circuit breaker #7



Key switch



Circuit breaker #8



Jack-point

## CONTROLS AND INSTRUMENTS

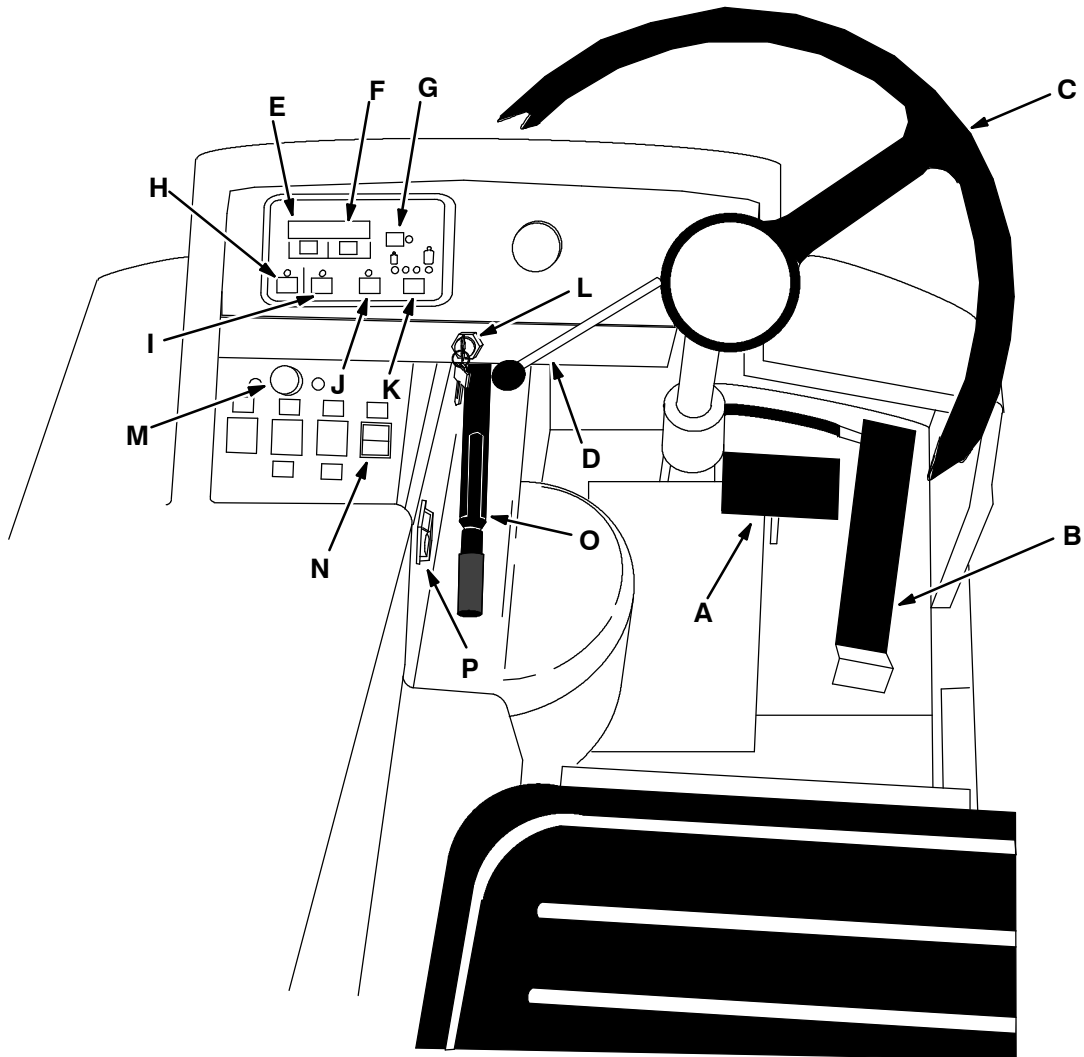

10639

- A. Brake pedal
- B. Directional pedal
- C. Steering wheel
- D. Solution lever
- E. Battery discharge indicator
- F. Hour meter
- G. Recovery tank full indicator
- H. ES™ switch (Option)
- I. Edge scrub switch
- J. Rear squeegee switch
- K. Scrub switch
- L. On-off key switch
- M. Horn button
- N. Operating lights switch/revolving light switch
- O. Parking brake
- P. Power wand switch (Option)

**BRAKE PEDAL**

The brake pedal stops the machine.

**Stop:** Take your foot off the directional pedal and let it return to the neutral position. Step on the brake pedal.

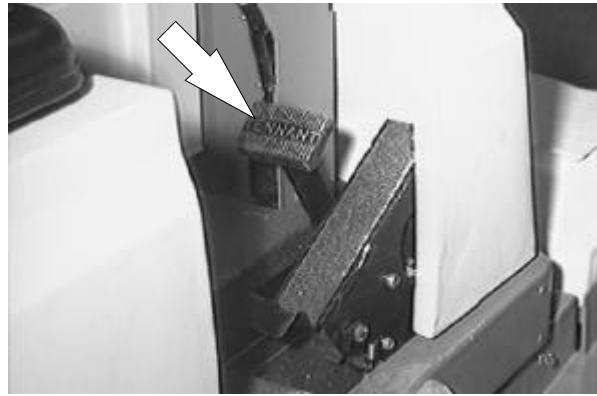
**DIRECTIONAL PEDAL**

The directional pedal controls direction of travel and the propelling speed of the machine. You change the speed of the machine with the pressure of your foot; the harder you press the faster the machine travels.

The machine will coast for a short distance before changing direction when it is moving, and the direction is reversed with the directional pedal. Use the brake pedal to stop the machine.

**Forward:** Press the top of the directional pedal with the toe of your foot.



**Reverse:** Press the bottom of the directional pedal with the heel of your foot.



## OPERATION

Neutral: Take your foot off the directional pedal and it will return to the neutral position.



### STEERING WHEEL

The steering wheel controls the machine's direction. The machine is very responsive to the steering wheel movements.

Left: Turn the steering wheel to the left.

Right: Turn the steering wheel to the right.

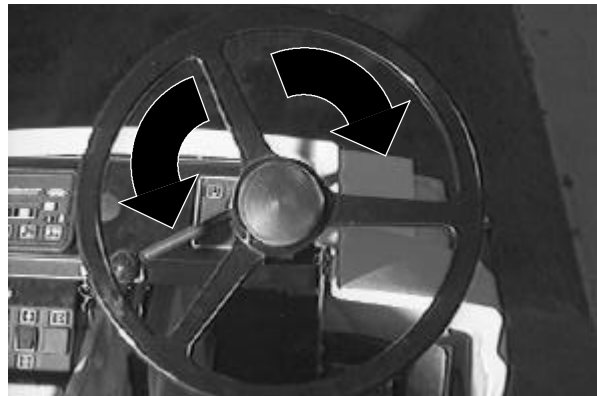

### SOLUTION LEVER

The solution lever controls the amount of solution flow to the floor.

Increase: Move the lever up.

Decrease: Move the lever down.

Stop: Move the lever all the way down.

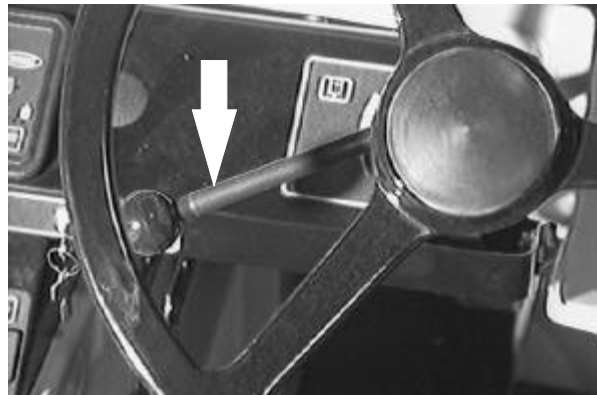

### BATTERY DISCHARGE INDICATOR

The battery discharge indicator shows the charge level of the batteries with a segmented display.

When the batteries are fully charged, all the segments are lit. As the batteries discharge, the segments shut off.

The batteries should be recharged when all the segments have shut off. At this point, the scrubbing functions will automatically shut off to alert the operator of the battery condition. The squeegee and vacuum can be operated, with the rear squeegee switch, for an additional 30 seconds to pick up any excess water.

*NOTE: Do not charge the batteries more often than is necessary to prolong the life of the batteries. Do not charge the batteries with a "top off" charge if there is enough remaining charge in the batteries for the next machine use. Discharge the batteries to a 20% level, when the battery discharge indicator segments shut off, before fully charging the batteries. Do not allow the batteries to become completely discharged as this will also damage the batteries. See BATTERIES in the MAINTENANCE section.*

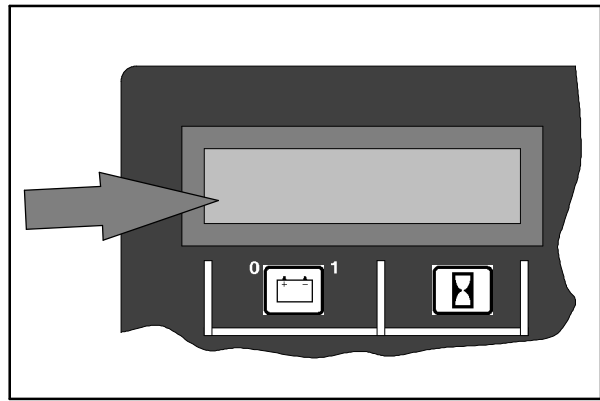

10658

### HOURLMETER

The hourmeter records the number of hours the machine has been operating. This information is useful when maintaining the machine.

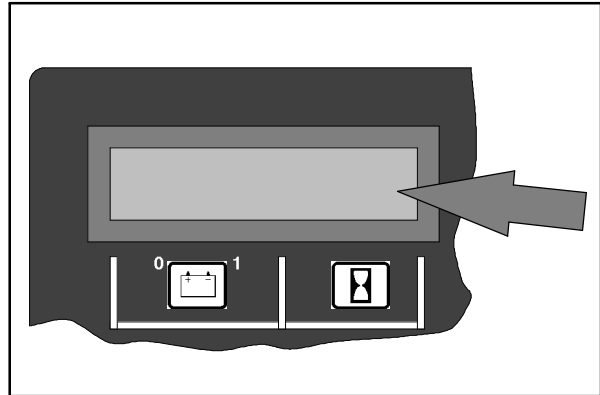

10659

## CONTROL PANEL MESSAGE DISPLAY

The hour meter and battery discharge indicator display also logs and displays messages to the operator. When a scheduled maintenance interval has passed, the control panel will internally log the event and display a message the next time the machine is powered on. See the chart below for the normal operating messages. If any messages appear other than those listed in the chart, contact your service personnel.

Message	Description
Tanks Full	The auto-fill has turned off. The tanks are filled to the proper level.
Rec. Tank Full	Recovery tank is full.
XX hour check	Check the Maintenance Chart for the scheduled maintenance at the number of hours stated in the message.
XX hour lube	Check the Maintenance Chart for the scheduled maintenance at the number of hours stated in the message.
Breaker CB3	Brush circuit breaker has tripped for the right brush motor. The circuit breaker must be reset before resuming scrubbing.
Breaker CB4	Brush circuit breaker has tripped for the left brush motor. The circuit breaker must be reset before resuming scrubbing.
Breaker CB5	Brush circuit breaker has tripped for the center brush motor (MaxPro™ 1200 option). The circuit breaker must be reset before resuming scrubbing.

To remove the message from the hour meter and battery discharge indicator display, turn the machine power off and then back on again.

The message display language can be changed. The available languages are:

English	Swedish
Dutch	Danish
Italian	Norwegian
Spanish	Finnish
French	Portuguese
German	Japanese

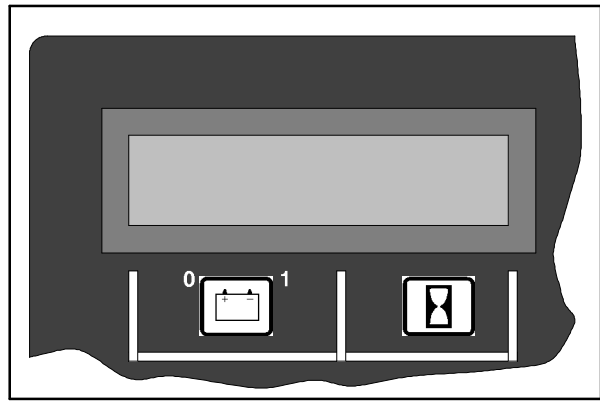

10660

CHANGING MESSAGE DISPLAY LANGUAGE

1. With the machine powered off, press and hold the scrub and edge scrub switches.

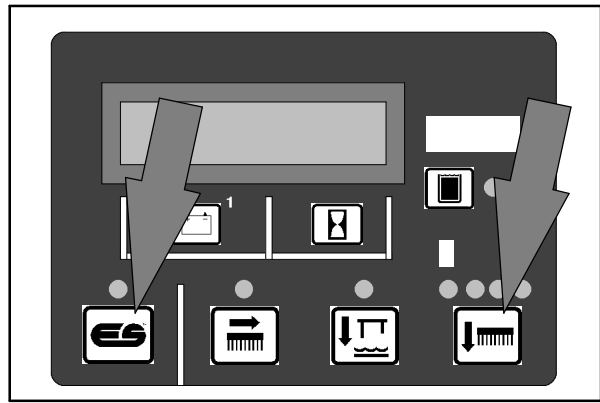

10734

2. Turn the machine power on.
3. Continue pressing the scrub and edge scrub switches for 5 more seconds.
4. Release the scrub and edge scrub switches.

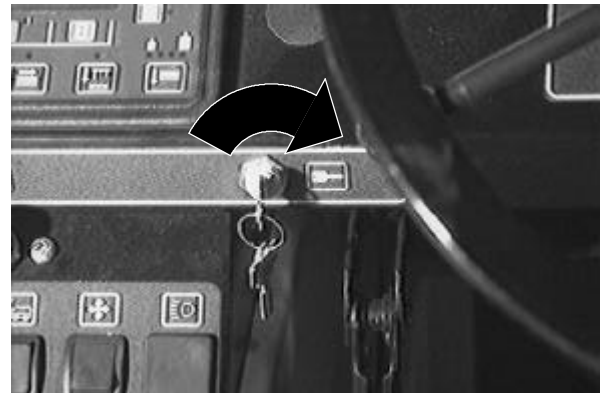

5. Press the ES™ switch to scroll through the list of languages until the desired language is displayed.
6. Turn the machine power off, and the new language will be stored in the control panel.

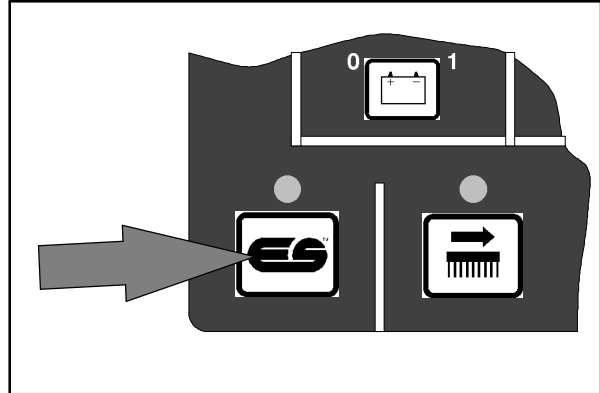

10662

RECOVERY TANK FULL INDICATOR

The recovery tank full indicator comes on when the recovery tank is full.

If the recovery tank full indicator stays on for more than 7 seconds, the “Rec. Tank Full” message will appear in the hourmeter display. The scrub brushes and vacuum will shut off, and the rear squeegee will raise.

To pick up excess water after the vacuum has shut off and the rear squeegee has raised, press and hold the rear squeegee switch.

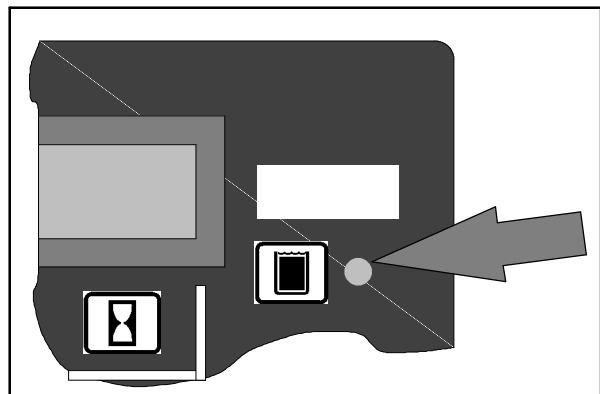

10661

*Note: Do not overfill the recovery tank. Overfilling the recovery tank may damage the vacuum fans.*

## OPERATION

### ES™ SWITCH (OPTION)

The ES™ switch turns on and off the solution recycling system.

On: Press the switch. The indicator will light.

Off: Press the switch.

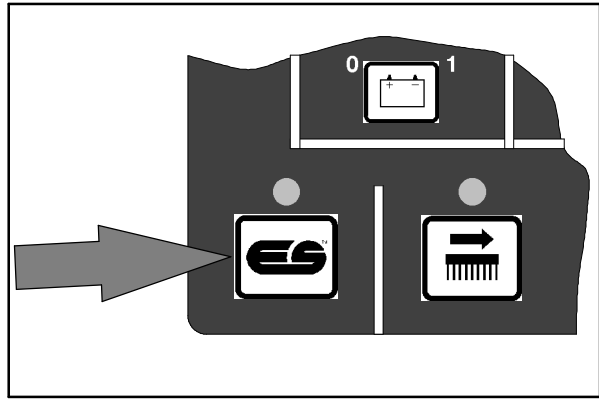

10662

### EDGE SCRUB SWITCH

The edge scrub switch extends the scrub head to the right to allow close edge scrubbing.

On: Press the switch during normal scrubbing. The indicator will light.

Off: Press the switch again.

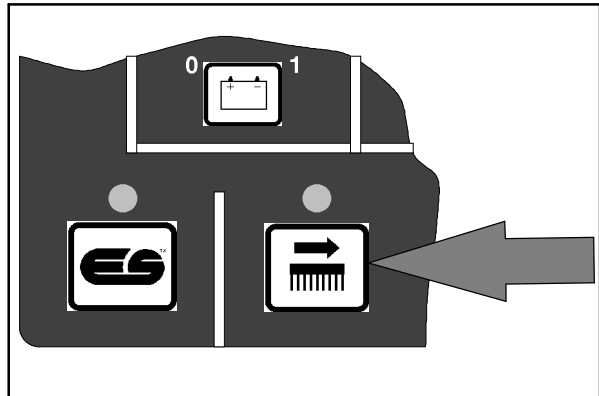

10663

### REAR SQUEEGEE SWITCH

The rear squeegee switch, along with the direction of travel, controls the rear squeegee position and scrubbing vacuum fan.

Lower squeegee and start vacuum: Press the switch. The indicator will light.

Raise squeegee and stop vacuum: Press the switch.

The rear squeegee lifts when the machine travels in reverse. This prevents the rear squeegee from being damaged when reversing the machine. The rear squeegee will lower again when the machine travels forward.

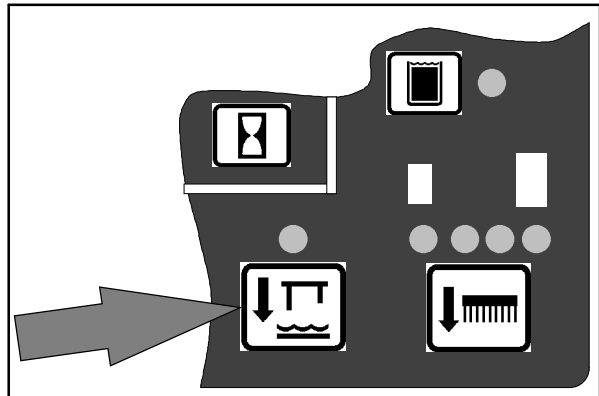

10880



## SCRUB SWITCH

The scrub switch controls the scrubbing operations. The scrub switch also sets the scrub brush pressure.

The scrubbing operations include the following. The scrub head lowers and the brushes turn on. The rear squeegee will lower and the vacuum will start. Also, the optional ES™ system will start.

**Start scrubbing:** Press the switch. The indicators will light to the preset brush pressure. The scrubbing system will start when the machine moves forward.

*NOTE: The brush pressure setting, the edge scrub, and the ES™ system will default to the last setting used when the scrubbing operations are started again.*

**Stop scrubbing:** Press the switch. The indicators will go off. First the scrub brushes will stop and raise, then the rear squeegee will raise and the vacuum will shut off.

**Scrub brush pressure:** Press and hold the scrub switch. The brush pressure will scroll through the four settings. Whatever pressure setting is selected when the switch is released, will be the new default brush pressure setting.

The brush pressure has four positions. Under normal conditions, the brush pressure should be set in the minimum settings. Under heavy grime conditions, the brush pressure should be set in the maximum settings. Travel speed and floor conditions will affect the scrubbing performance.

*NOTE: The rear squeegee will raise and the vacuum will shut off when the machine travels in reverse. The squeegee will lower and the vacuum starts again when the machine travels forward.*

*NOTE: The scrub brushes will stop when the machine is stopped for a short time. The brushes will start again when the machine travels forward.*

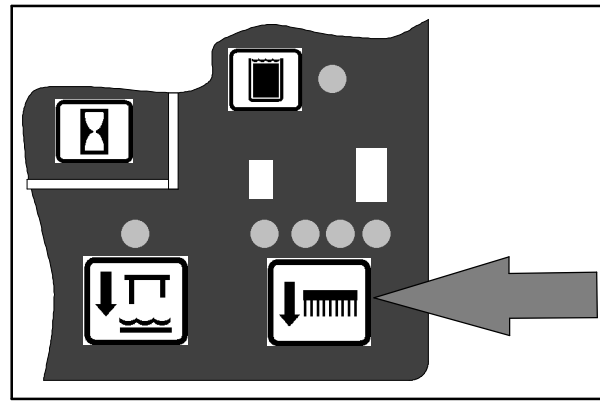

10881

## OPERATION

### ON-OFF KEY SWITCH

The on-off key switch controls machine power with a key.

On: Turn the key clockwise all the way.

Off: Turn the key counter-clockwise.

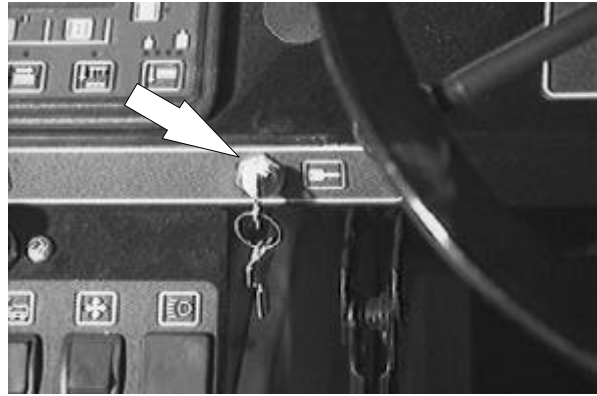

### HORN BUTTON

The horn button operates the horn.

Sound: Press the button.



### OPERATING LIGHTS SWITCH (OPTION)

The operating lights switch powers on and off the headlights, taillights, and hazard light option.

On: Press the top of the switch.

Off: Press the bottom of the switch.

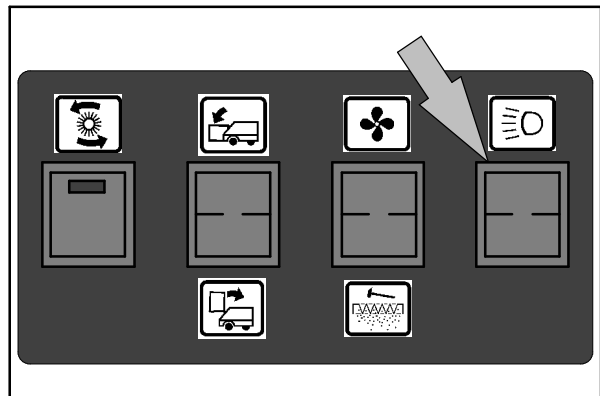

10906

**PARKING BRAKE**

The parking brake lever sets and releases the rear wheel brakes.

Set: Pull the parking brake lever up.

**FOR SAFETY: Before leaving or servicing machine; stop on level surface, set parking brake, turn off machine and remove key.**



Release: Push the parking brake lever down.

**POWER WAND SWITCH (OPTION)**

The power wand switch turns on and off the power wand solution system.

On: Press the top of the switch. The switch will light up.

Off: Press the bottom of the switch.



# OPERATION

## CIRCUIT BREAKERS

The circuit breakers are resettable electrical circuit protection devices. They stop the flow of current in the event of a circuit overload. Once a circuit breaker is tripped, reset it manually by pressing the reset button after the breaker has cooled down.

If the overload that caused the circuit breaker to trip is still there, the circuit breaker will continue to stop current flow until the problem is corrected.

The fuse is a one-time circuit protection device designed to stop the flow of current in the event of a circuit overload. Never substitute higher value fuses than those specified in this manual.

The circuit breakers are located to the left of the operator's compartment near the machine and battery connectors and on the control boxes. The fuses are located in the main control box.

The chart shows the circuit breakers and fuses, and the electrical components they protect.

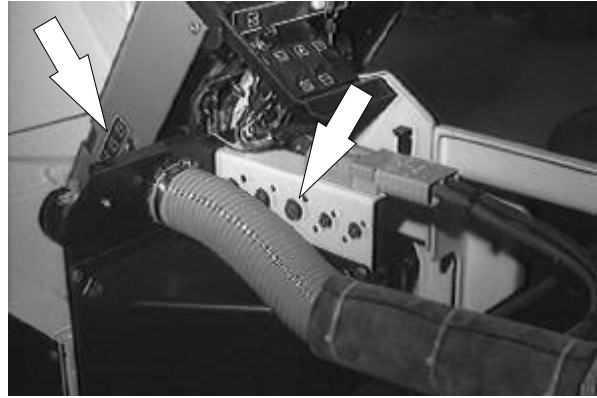

Circuit Breaker	Rating	Circuit Protected
CB1	20 A	Scrubbing vacuum fan motor
CB2	20 A	Scrubbing vacuum fan motor
CB3	40 A	Right scrub brush motor
CB3	50 A	Heavy duty right scrub brush motor (option)
CB4	40 A	Left scrub brush motor
CB4	50 A	Heavy duty left scrub brush motor (option)
CB5	40 A	Center scrub brush motor (option)
CB6	2.5 A	Control Circuit
CB7	15 A	Control panel
CB8	15 A	Horn, hazard and operating lights (option)

**SOLUTION TANK DRAIN HOSE**

The solution tank drain hose is used to drain the solution tank. Drain the solution tank by removing the drain hose cap from the tank access cap. Pull out the solution tank hose and remove the drain hose end cap.

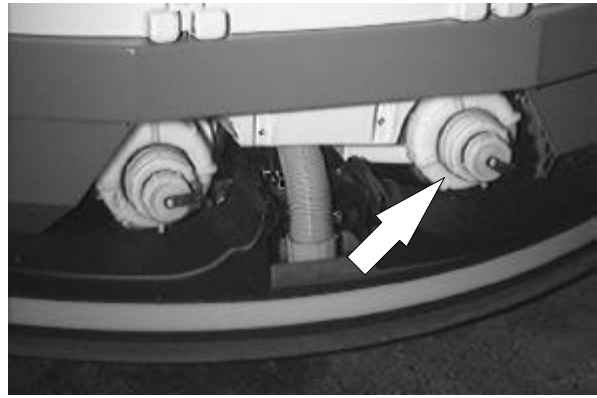
**RECOVERY TANK DRAIN HOSE**

The recovery tank drain hose is used to drain the recovery tank. Drain the recovery tank by removing the drain hose cap from the tank access cap. Pull out the recovery tank hose and remove the drain hose end cap.

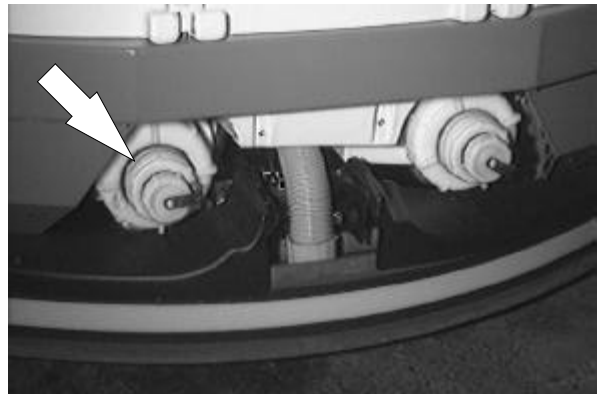
**POSITIVE SOLUTION CONTROL DRAIN (OPTION)**

For machines with the positive solution control drain option, remove the dust cap. Connect the drain hose to the solution control drain and open the drain valve.

**OPERATOR SEAT**

The operator set is a fixed back style with a forward-backward adjustment.

Adjust: Remove the seat mounting bolts, move the seat to the desired position; reinstall and tighten the bolts.



### HOW THE MACHINE WORKS

---

The steering wheel controls the direction of machine travel. The directional pedal controls the speed and forward/reverse directions. The brake pedal slows and stops the machine.

The scrub components of the machine are a solution tank, scrub brushes, rear and side squeegees, a vacuum system, and a recovery tank.

Water and detergent, from the solution tank, flow to the floor through a solution valve to the scrub brushes. The brushes scrub the floor. As the machine is moved forward the squeegees wipe the dirty solution off the floor, which is then picked up and drawn into the recovery tank.

When using the ES™ mode, the solution in the recovery tank is filtered and returned to the solution tank to be reused.

Two different widths of scrub heads are available for the machine. The MaxPro™ 1000 scrub head contains two disk scrub brushes. The MaxPro™ 1200 scrub head contains three disk scrub brushes.

When finished scrubbing, drain and clean the recovery tank. If using the ES™ system, drain and clean the solution tank, and clean the ES™ filter.

---

**PRE-OPERATION CHECKLIST**

---

Check over this list of items before operating the machine:

- Check under the machine for leaks.

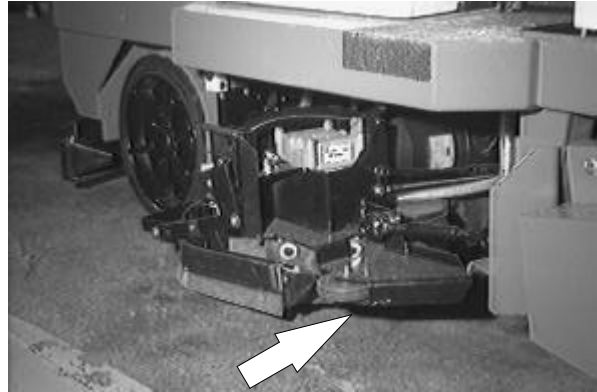

- Check the brakes and steering for proper operation.

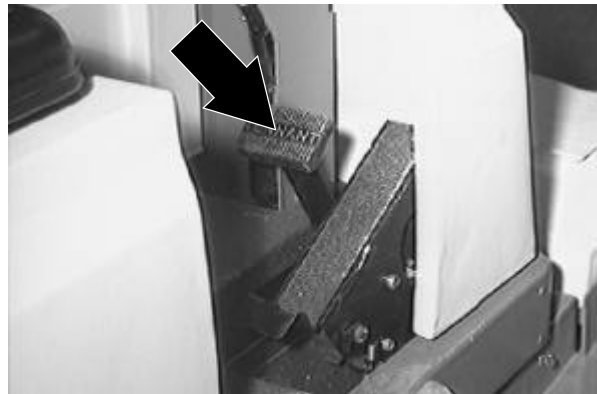

- Check the squeegee for proper deflection. Check the squeegee blade for wear, rounded edges, nicks, or cuts.

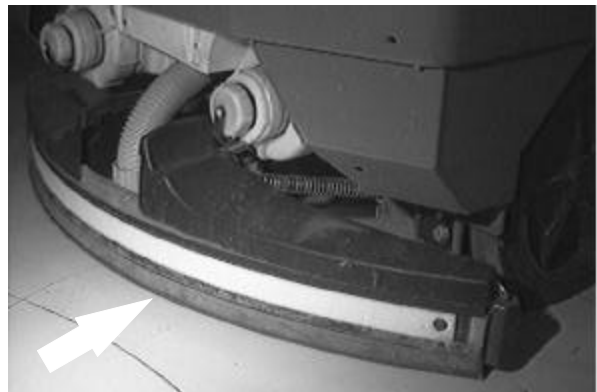

# OPERATION

## STARTING THE MACHINE

1. You must be in the operator's seat with the directional pedal in neutral, and your foot on the brake pedal or with the parking brake set.
2. Turn the machine power on.



3. Release the machine parking brake.



## FILLING THE TANKS

1. Start the machine.
2. Drive the machine to the filling site.





- Turn the machine power off.

**FOR SAFETY: Before leaving or servicing machine; stop on level surface, set parking brake, turn off machine and remove key.**

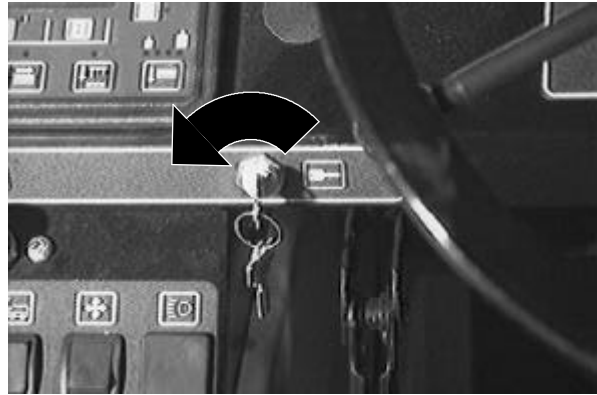

- Set the parking brake.



- Open the tank cover and pour the required amount of detergent into the solution tank fill opening. Fill the solution tank with water to 75 mm (3 in) below the tank opening.

*If you **do not** want to use the ES™ system, make sure the ES™ system is off. **DO NOT** fill the recovery tank.*

***NOTE:** If you are going to scrub in the ES™ mode, the recovery tank can be partially filled to extend scrub time. Make sure the ES™ system is on.*

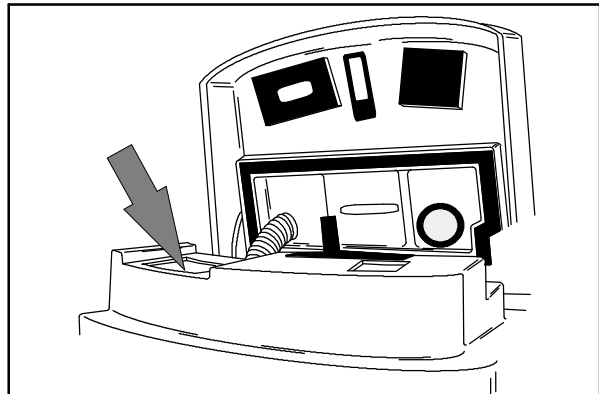

05921

**FOR SAFETY: Follow mixing and handling instructions on chemical containers.**

## OPERATION

6. ES™ mode: Connect the hose and adaptor from the water source to the auto-fill connection on the machine.

*NOTE: When using the auto-fill feature on the ES™ machine, both tanks should be empty to prevent overfilling of the tanks.*

Turn the machine power on, and turn on the water source. The auto-fill will automatically fill the tanks to the proper level for ES™ operation. When the auto-fill stops, the message “Tanks Full” will appear on the hourmeter display.

The tanks can also be filled manually. Fill the solution tank with water to 75 mm (3 in) below the tank opening. Fill the recovery tank half full.

*NOTE: Floor conditions, water condition, amount of soilage, types of soilage, and brush action all play an important role in determining the type and concentration of detergent used. For specific recommendations, contact your Tennant representative.*



**WARNING: Flammable materials can cause an explosion or fire. Do not use flammable materials in tank(s).**

7. Close the tank cover.

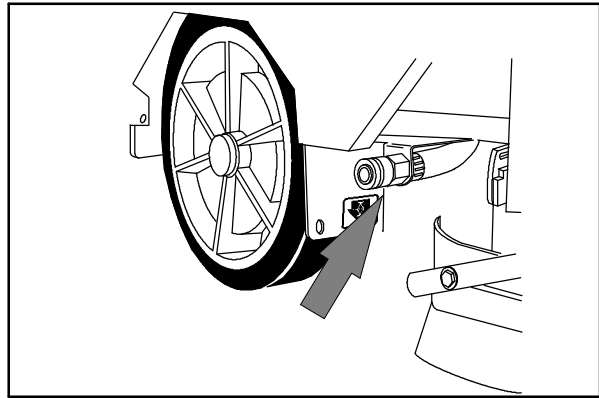

05922

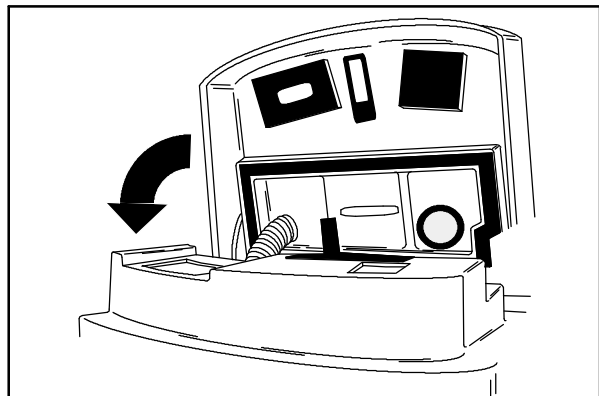

05921

## SCRUBBING AND BRUSH INFORMATION

Pick up oversized debris before scrubbing. Pick up pieces of wire, string, twine, etc., which could become wrapped around the scrubbing brushes.

Plan the scrubbing in advance. Try to arrange long runs with minimum stopping and starting. Do an entire floor or section at one time.

Drive as straight a path as possible. Avoid bumping into posts or scraping the sides of the machine. Overlap the scrub paths by several centimeters (a few inches).

Avoid turning the steering wheel too sharply when the machine is in motion. The machine is very responsive to the movement of the steering wheel. Avoid sudden turns, except in emergencies.

When scrubbing dead end aisles, start at the closed end of the aisle and scrub your way out.

Adjust the machine speed, scrub brush pressure, and solution flow as required when scrubbing. Use minimum scrub brush pressure and solution flow required for the best results. The machine has an edge clean feature for scrubbing against an edge.

If you see poor scrubbing performance, stop scrubbing and refer to *MACHINE TROUBLESHOOTING*.

For best results, use the correct brush type for your cleaning application. The following are recommended brush applications.

**Non-scuff polypropylene scrub brush** - This brush uses a softer, general purpose polypropylene bristle to lift lightly compacted soilage without scuffing high-gloss coated floors.

**Nylon scrub brush** - Recommended for scrubbing coated floors. Cleans without scuffing.

**Super abrasive bristle scrub brush** - Nylon fiber impregnated with abrasive grit to remove stains and soilage. Strong action on any surface, performing well on buildup, grease, or tire marks.

**Stripping pad** - This brown pad is for stripping floors. Quickly and easily cuts through old finish to prepare the floor for re-coating.

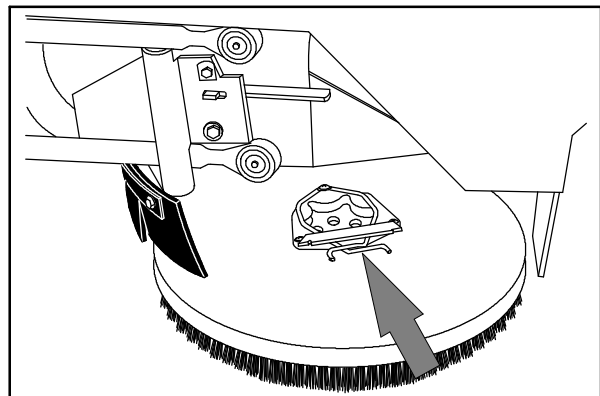

05939

## OPERATION

**Scrubbing pad** – This blue pad is for scrubbing floors. Removes dirt, spills and scuffs, leaving a clean surface ready for re-coating.

**Buffing pad** – This red pad is for buffing floors. Quickly cleans and removes scuff marks while polishing the floor to a high gloss.

**Polishing pad** – This white pad is for polishing floors. Maintains a high gloss. Use for buffing very soft finishes and lower traffic areas, or use for polishing soft waxes on wood floors.

### SCRUBBING

1. Start the machine.
2. Drive the machine to the area to be cleaned.



3. Press the scrub switch.

When the machine travels forward, the rear squeegee will lower, the scrubbing vacuum will start, the scrub head will lower, and the scrub brushes will start.

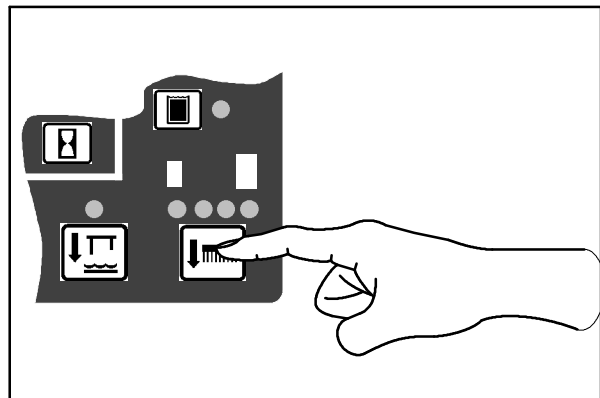

10884

4. Move the solution lever up to start the solution flow.

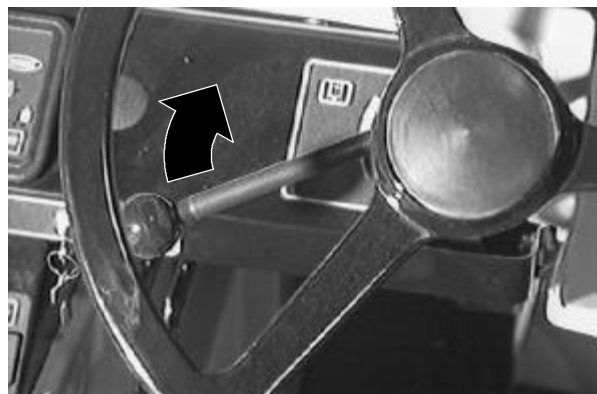

5. To scrub close to edges with the MaxPro™ 1000, press the edge scrub switch.
6. Drive the machine forward and scrub as required.

**⚠ WARNING: Flammable materials or reactive metals can cause an explosion or fire. Do not pickup.**

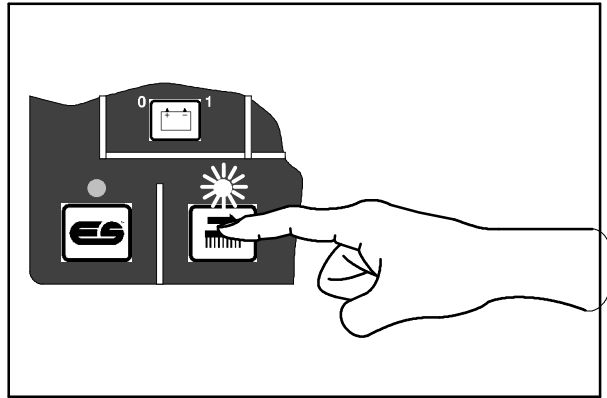

10883

7. Adjust the solution flow to the floor as needed.

*NOTE: When approaching a corner, reduce the solution flow just before turning the corner. Increase the solution flow once the machine has completed the turn.*

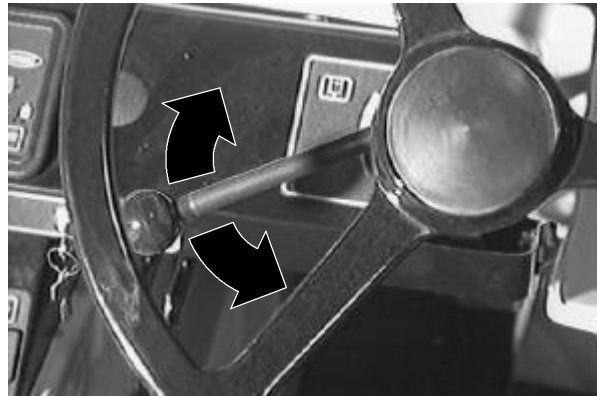

8. Adjust the brush pressure for the cleaning application.

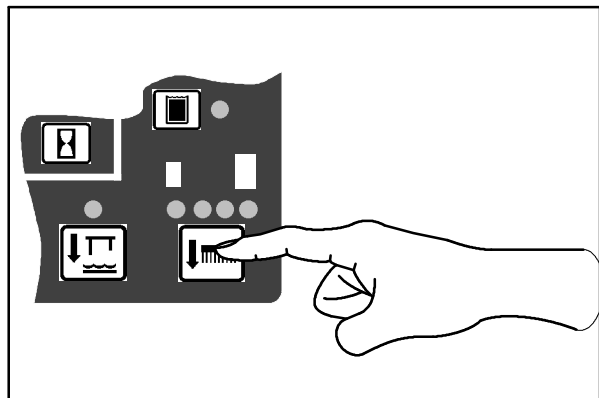

10884

## DOUBLE SCRUBBING

Double scrubbing is a method for removing heavy floor accumulations. This is done by making two or more passes over the area to be cleaned with the machine.

First, make a pass over the area scrubbing with the side and rear squeegees up. This dispenses solution over the area allowing the solution to soak on the floor. Let the solution remain on the floor for 15 to 20 minutes. Then make a second pass scrubbing with the squeegees down.

Lock the side squeegees up during double scrubbing.

**FOR SAFETY: When using machine, go slow on inclines and slippery surfaces.**

## LOCKING UP SIDE SQUEEGEES

1. Turn the machine power off.

**FOR SAFETY: Before leaving or servicing machine; stop on level surface, set parking brake, turn off machine and remove key.**

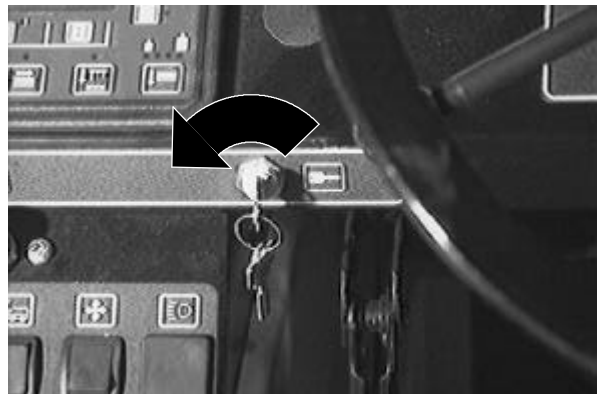

2. Set the parking brake.



3. Lift the left side squeegee up.

4. Turn the squeegee stop towards the front of the machine and hold in place.
5. Lower the side squeegee against the stop.

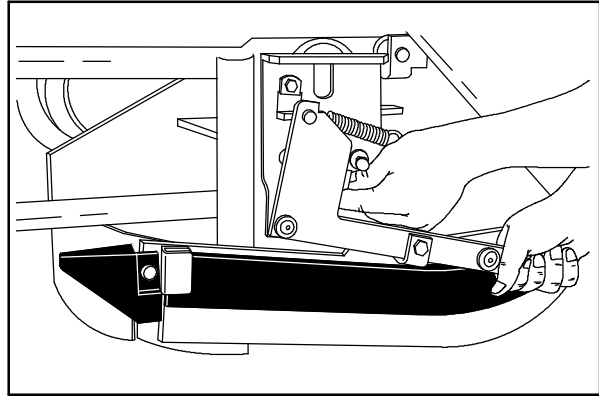

05927

6. Repeat the steps with the right side squeegee for the MaxPro™ 1000 scrub head. For the MaxPro™ 1200 scrub head, disconnect the lift chain from the machine frame. Lift up the right side of the scrub head and connect the lift chain to the bottom of the side bracket.

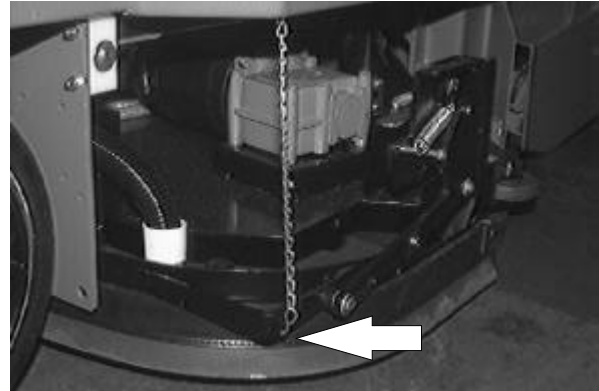

### UNLOCKING SIDE SQUEEGEES

1. Turn the machine power off.

**FOR SAFETY: Before leaving or servicing machine; stop on level surface, set parking brake, turn off machine and remove key.**

2. Set the parking brake.
3. Lift the left side squeegee. The stop will move out of the way.
4. Lower the side squeegee to the floor.
5. Repeat the steps with the right side squeegee on the MaxPro™ 1000 scrub head. For the MaxPro™ 1200 scrub head, lift up the right side of the scrub head and disconnect the lift chain from the bottom of the side bracket. Lower the scrub head. Connect the lift chain to the main frame.

## STOP SCRUBBING

1. Move the solution flow lever all the way down to stop solution flow to the floor.

ES™ mode: Press the ES™ switch to turn off the ES™ system.

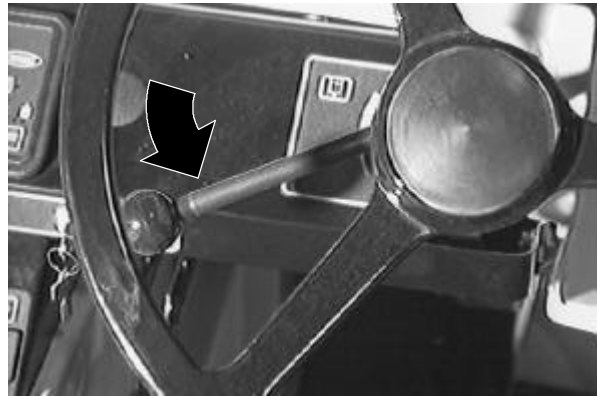

2. Press the scrub switch.

The scrub head will raise, the scrub brush motors will stop, the rear squeegee will raise after a short delay, and the vacuum will shut off.

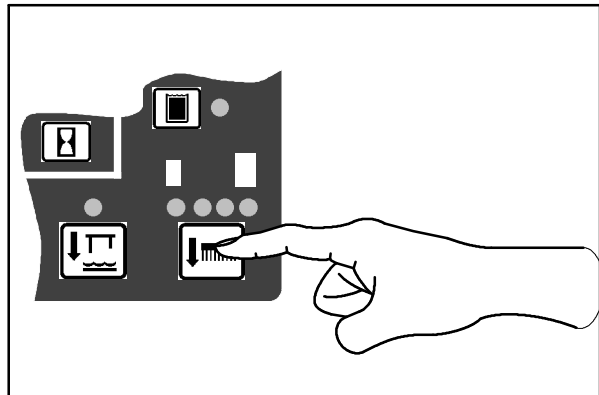

10884



## DRAINING AND CLEANING THE TANKS

When you are finished scrubbing, or when the recovery tank full indicator comes on, the recovery tank should be drained and cleaned. The solution tank then can be filled again for additional scrubbing.

If you used the machine in ES™ mode, the solution tank should also be drained and cleaned when you are finished scrubbing.

1. Stop scrubbing.
2. Drive the machine next to an appropriate disposal site.



3. Turn the machine power off.

**FOR SAFETY: Before leaving or servicing machine; stop on level surface, set parking brake, turn off machine and remove key.**

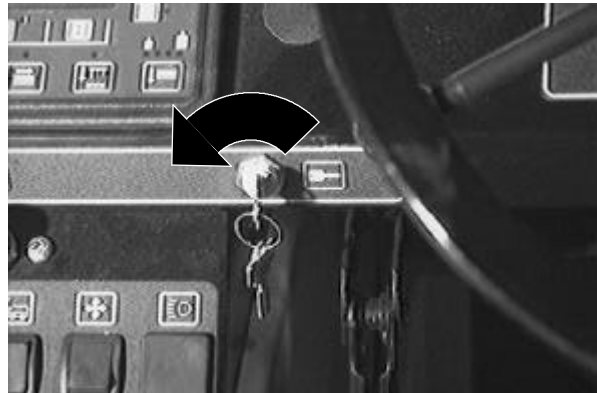

4. Set the parking brake.



## OPERATION

5. Unscrew the drain hose cap from the recovery tank drain access cap.
6. Pull out and place the drain hose next to the floor drain. Remove the drain end cap from the hose. Stand back because the solution rushes out of the drain hose.

ES™ mode: Unscrew the drain hose cap from the solution tank drain access cap and drain the solution tank.

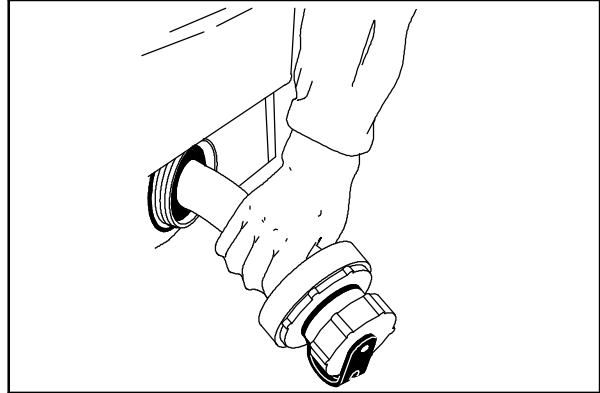

05914

For machines with the positive solution control drain option, remove the drain cap and connect the hose. Place the hose end next to the floor drain and open the drain valve.



7. Open the tank cover.
8. Spray the inside of the recovery tank. The recovery tank has two access caps, one on the side of the machine, and one at the tank drain.

ES™ mode: Flush out the solution tank with clean water through the fill opening.

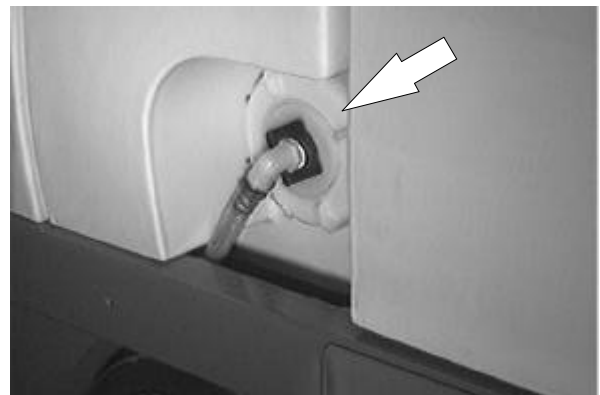

9. ES™ mode: Remove the ES™ filter from the recovery tank and clean. Place the filter back in the recovery tank. Place the drain end cap on the recovery tank drain hose, or close the drain valve. Then add enough water to the tank to cover the outlet filter and operate the ES™ pump to flush the ES™ system.

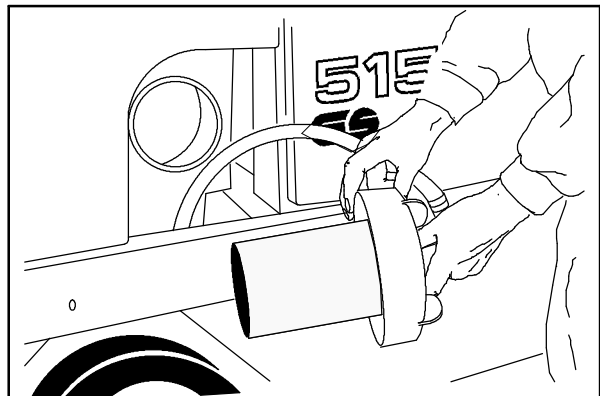

10916

10. Remove the vacuum inlet screen from the tank cover and clean. Place the inlet filter back in the tank cover.

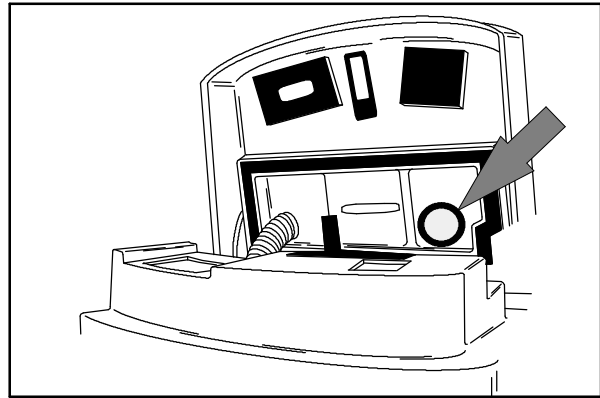

05921

11. For machines serial number 004868 and above, open the machine cover to gain access to the vacuum fan filter. Remove the knobs and the vacuum filter cover.

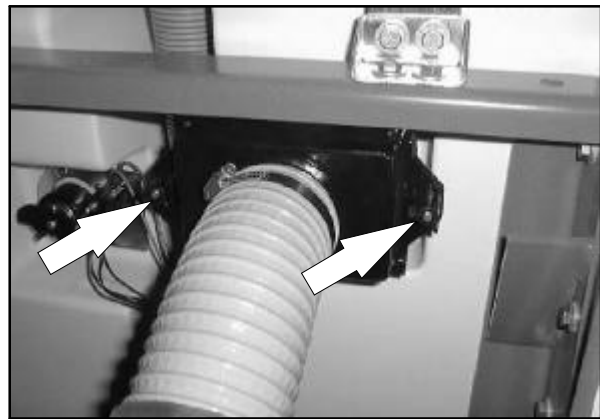

Remove and clean the vacuum fan filter by shaking the dust, using low pressure air, or rinsing pleats with low pressure water.

*NOTE: Be sure the vacuum fan filter is dry before reinstalling it in the machine.*

Insert the filter and place the cover back into the machine. Close the machine cover.

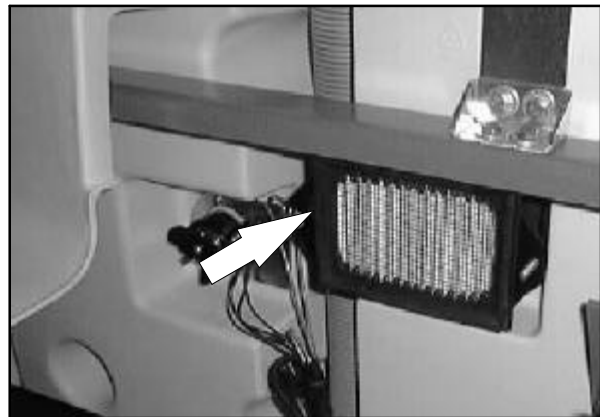

12. Place the drain end caps on the tank drain hoses. Push the drain hoses back into the tanks.

For machines with the positive solution control drain option, close the drain valve. Remove the hose and connect the drain cap.

### STOP THE MACHINE

1. Stop scrubbing.
2. Turn the machine power off.



3. Set the parking brake.

**FOR SAFETY: Before leaving or servicing machine; stop on level surface, set parking brake, turn off machine and remove key.**



**POST-OPERATION CHECKLIST**

Check over this list of items after you have finished scrubbing with the machine powered on:

- Check the battery charge level.

*NOTE: The reading on the battery discharge indicator is not accurate when the machine is first powered on. Operate the machine a few minutes before reading the charge level of the batteries.*

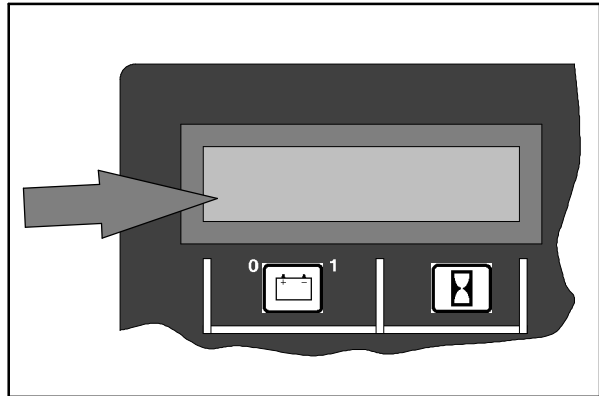

10658

Check over this list of items with the machine powered off:

- Check for wire, string, or twine wrapped around the brushes.

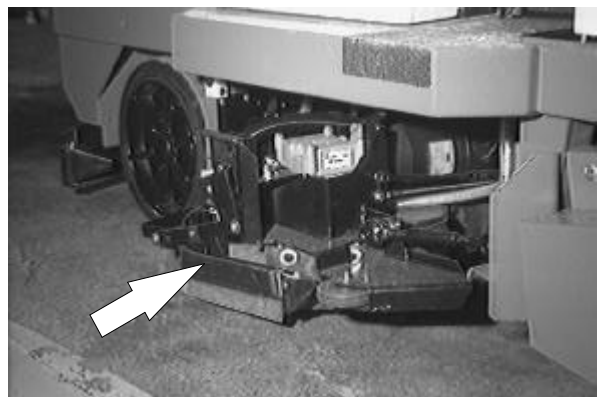

- Check the squeegees for wear or damage.

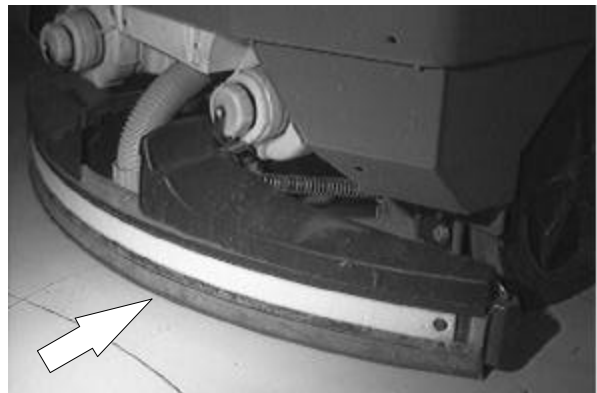

## OPERATION

- Drain and clean the recovery tank.

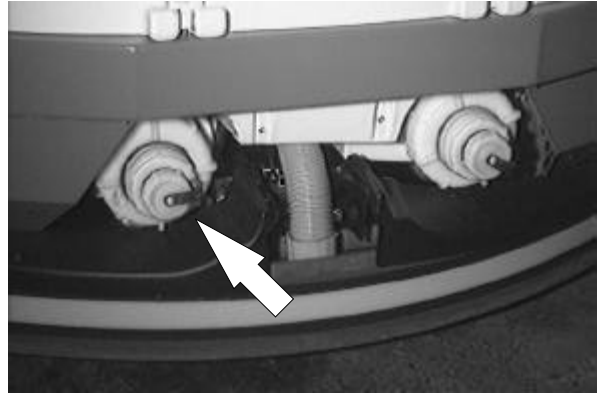

- ES™ machines: Drain and clean the solution tank. Clean the ES™ filter. Then add enough water to the tank to cover the outlet filter and operate the ES™ pump to flush the ES™ system.

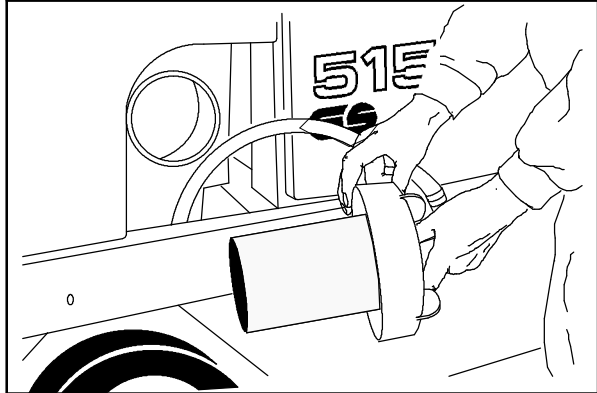

10916

- Check the vacuum hoses for obstructions.
- Check for any machine leaks.
- Check the service records to determine service requirements.

---

## OPERATION ON INCLINES

---

Drive the machine slowly on inclines.

**FOR SAFETY: When using machine, go slow on inclines and slippery surfaces.**

The maximum rated climb and descent incline with empty tanks is 8.5°, and with full tanks is 5.7°.

---

**OPTIONS**

---

**VACUUM WAND**

The vacuum wand uses the machine's vacuum system. The vacuum wand and hose allows pick-up of spills that are out of reach of the machine.

 **WARNING: Flammable materials or reactive metals can cause an explosion or fire. Do not pickup.**

1. Turn the machine power off.

**FOR SAFETY: Before leaving or servicing machine; stop on level surface, turn off machine.**

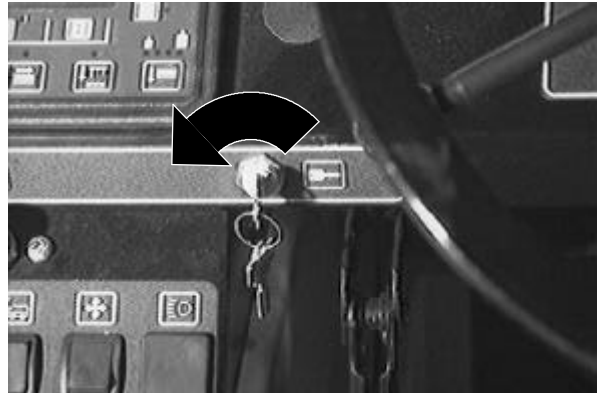

2. Set the parking brake.



## OPERATION

3. Remove the vacuum wand equipment from the tank cover.

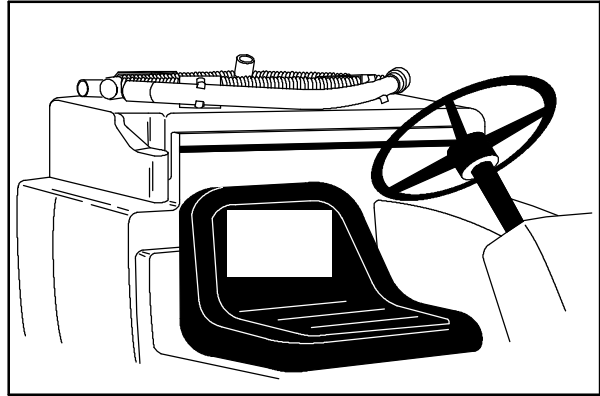

05929

4. Remove the squeegee suction hose from the top of the rear squeegee.

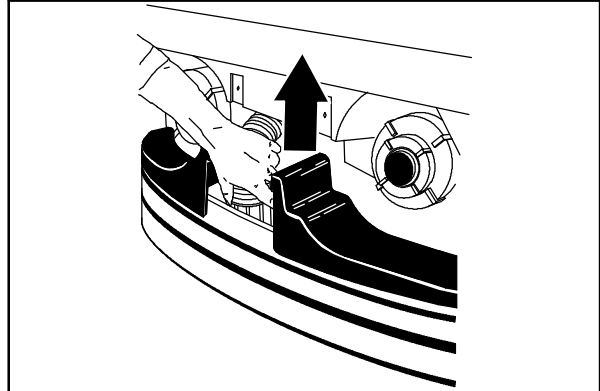

05930

5. Connect the vacuum wand hose and the squeegee suction hose and secure with the retainer clip.

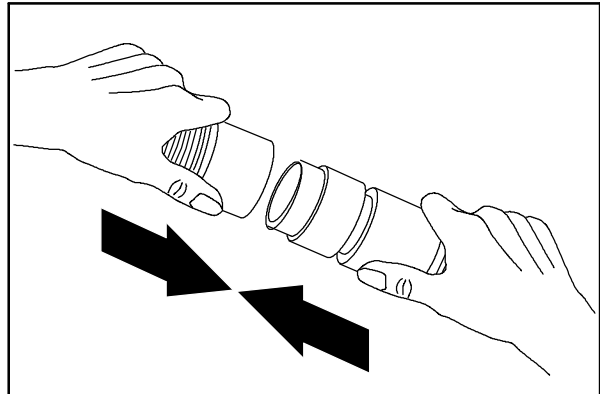

10945

6. Put together the wand and the wand hose.
7. Turn the machine power on.

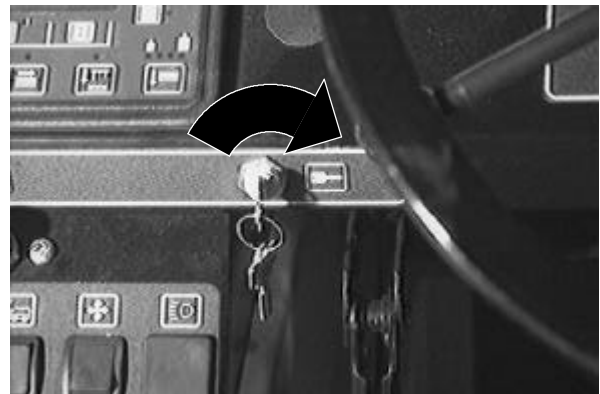



8. Press the rear squeegee switch to turn on the vacuum.

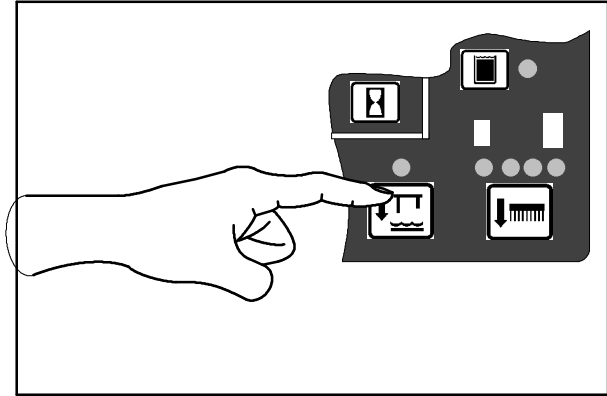

10885

9. Vacuum the floor.

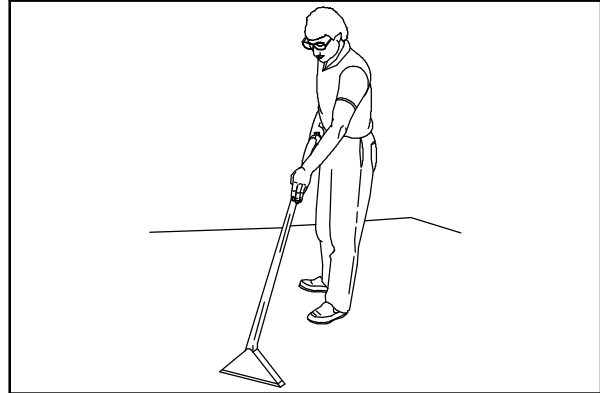

06599

10. When finished, shut off the vacuum with the rear squeegee switch.

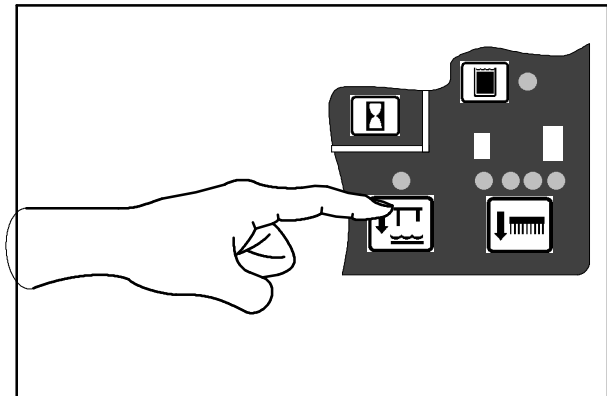

10885

11. Turn the machine power off.

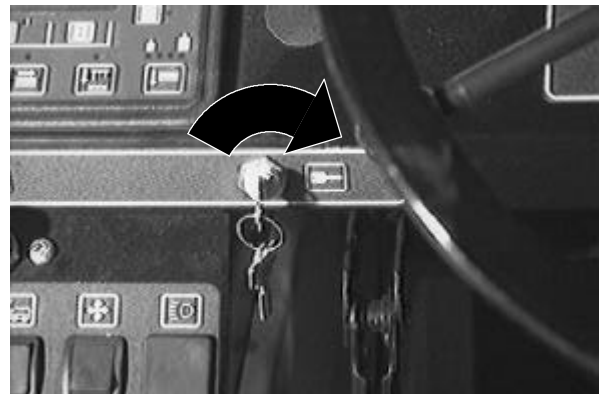

## OPERATION

12. Remove the retainer clip, and disconnect the vacuum hose from the squeegee suction hose.

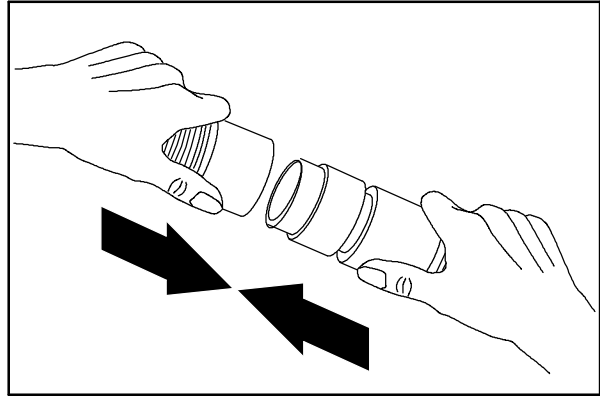

10945

13. Reconnect the squeegee suction hose to the top of the squeegee.
14. Clean and rinse the vacuum wand equipment.
15. Secure the vacuum wand equipment on top of the tank cover.

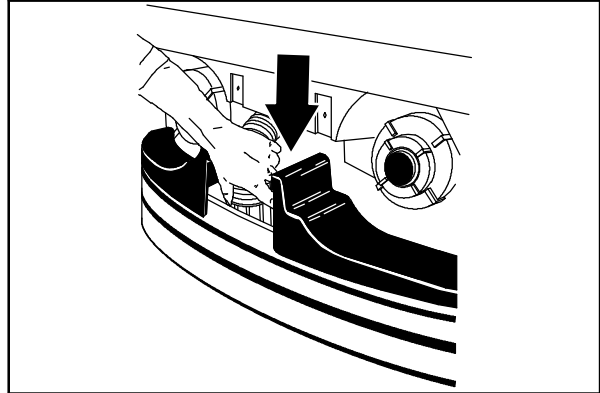

05930

**POWER WAND**

The power wand uses the machine's vacuum and solution systems. The power wand allows scrubbing of floors that are out of reach of the machine.

**⚠ WARNING: Flammable materials or reactive metals can cause an explosion or fire. Do not pickup.**

1. Turn the machine power off.

**FOR SAFETY: Before leaving or servicing machine; stop on level surface, turn off machine.**



2. Set the parking brake.



3. Remove the power wand equipment from the tank cover.
4. Remove the squeegee suction hose from the top of the rear squeegee.

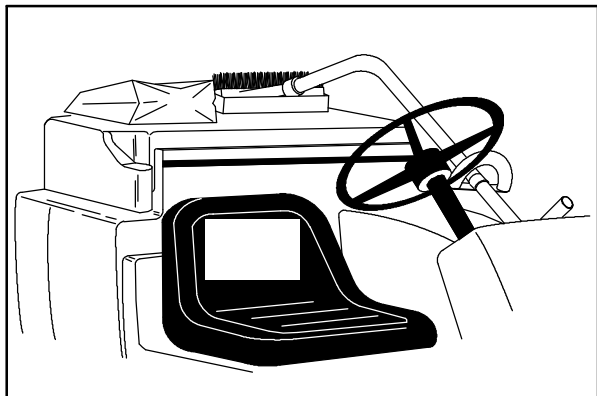

08067

## OPERATION

5. Connect the vacuum wand hose and the squeegee suction hose with the adaptor.

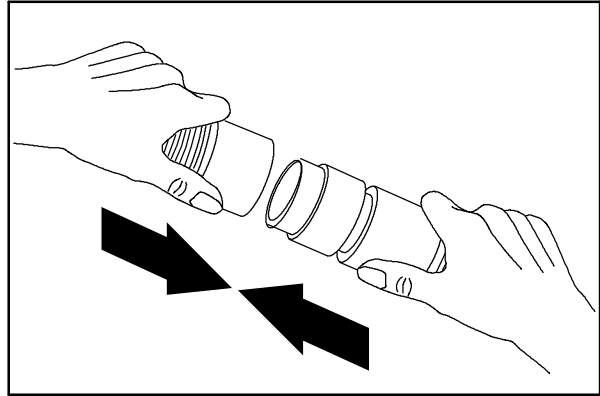

10945

6. Attach the end of solution hose to the quick-disconnect. Push the connector in until it stops. Pull on the hose to make sure it is connected.

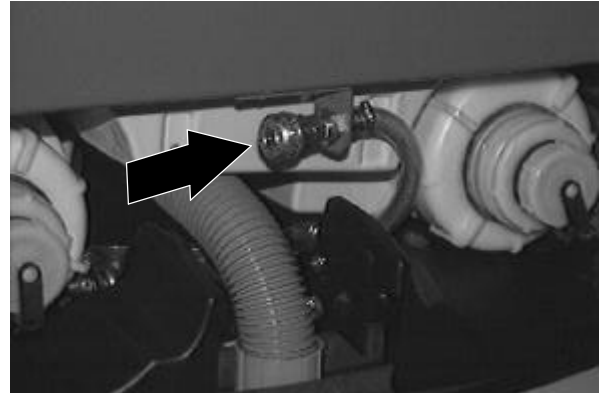

7. Attach the other ends of the solution and vacuum hoses to the power wand.

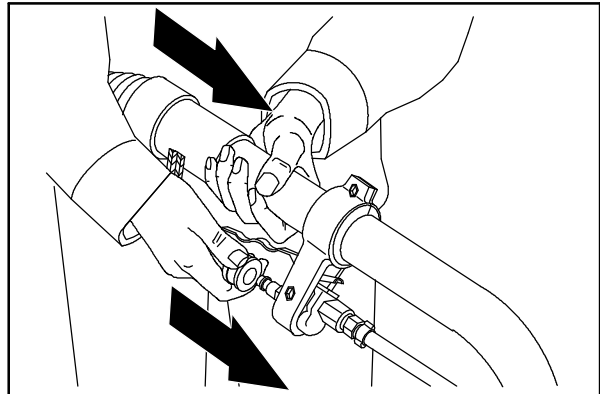

07320

8. Turn the machine power on.

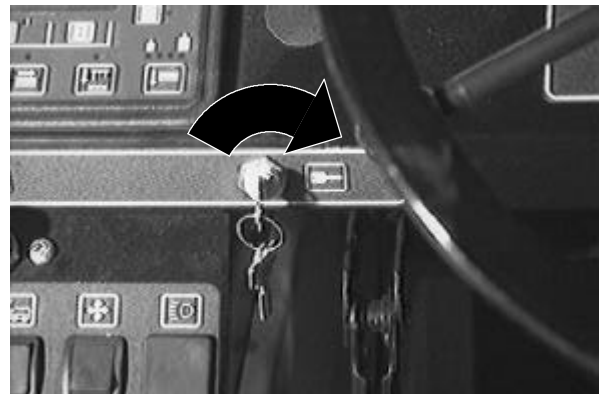

9. Press the rear squeegee switch to turn on the vacuum.

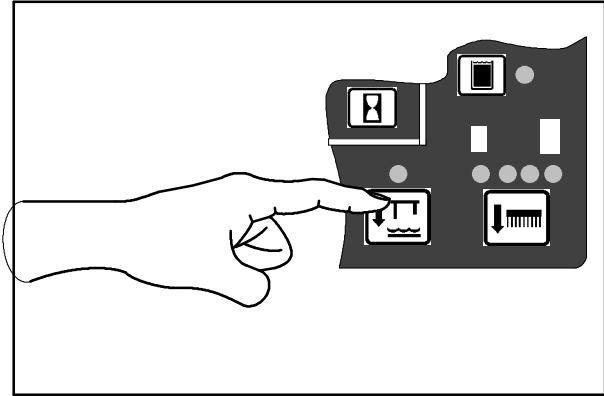

10885

10. Switch the power wand on.



11. Squeeze the solution lever on the power wand to spray solution on the floor. Scrub the floor with the brush side of the cleaning tool.

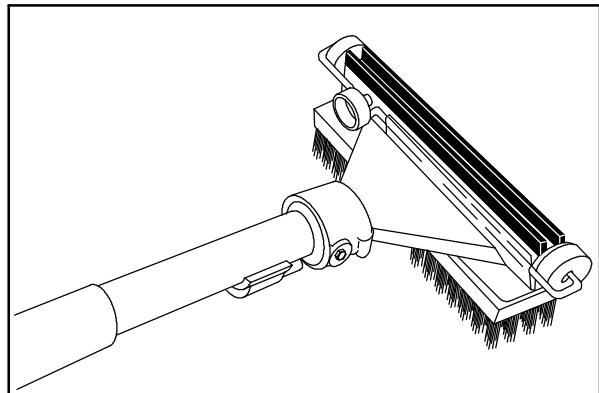

06601

12. Vacuum up the solution by turning over the cleaning tool so the squeegee side is down.

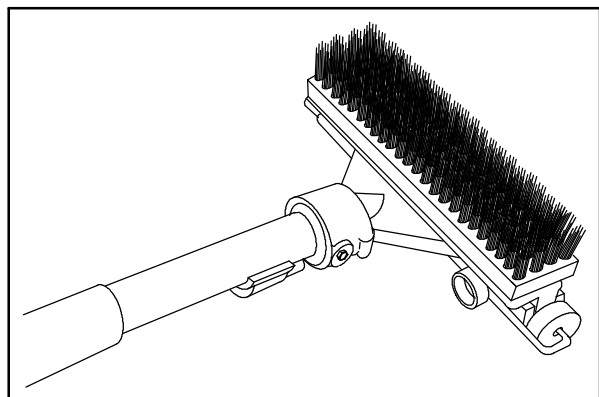

06202

## OPERATION

If the cleaning tool is hard to push or is not picking up the solution very well, adjust the roller wheels on the tool by turning the black adjustment knob.

*NOTE: The wheels are properly adjusted when the squeegee blades deflect slightly while the tool is pushed back and forth.*

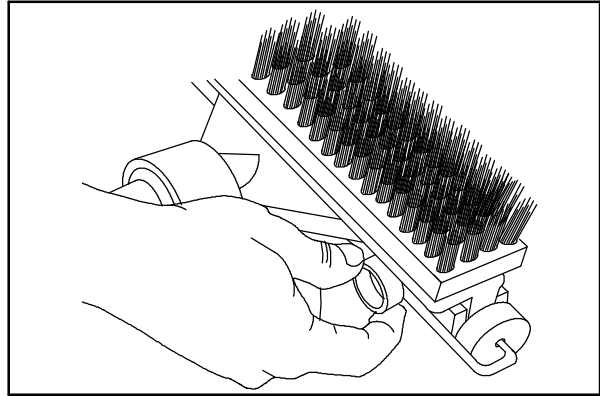

06604

13. When finished, switch the power wand off.



14. Press the rear squeegee switch to shut off the vacuum.

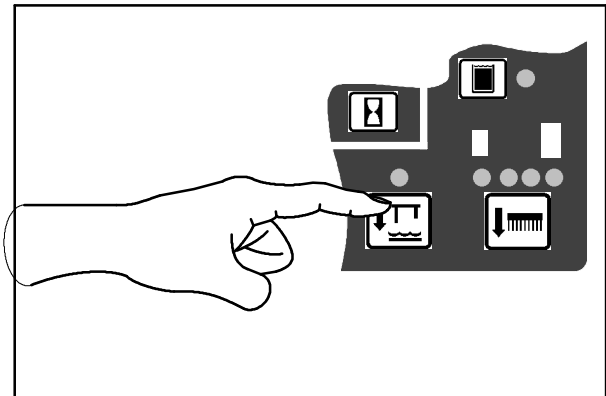

10885

15. Turn the machine power off.



16. Disconnect the solution hose from the machine.

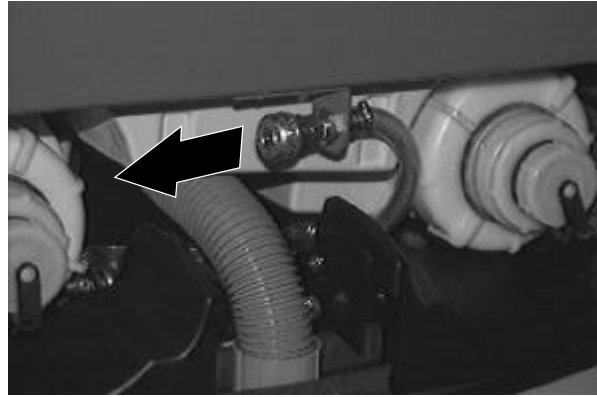

17. Remove the vacuum hose from the squeegee suction hose.

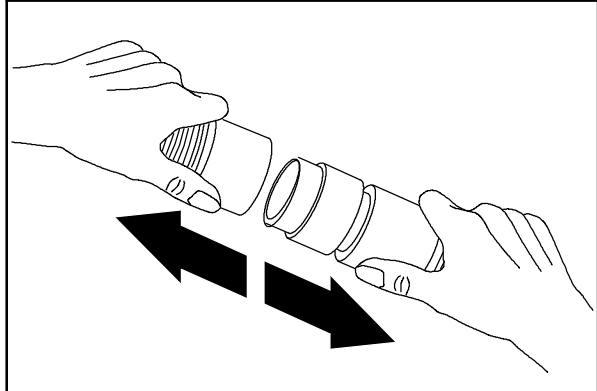

10946

18. Reconnect the squeegee suction hose to the squeegee.

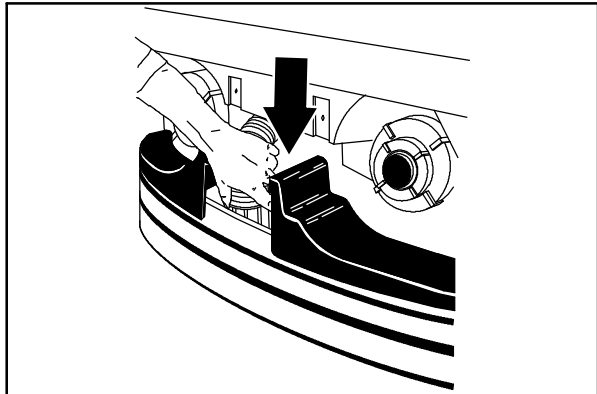

05930

19. Disconnect the other ends of the solution and vacuum hoses from the power wand.
20. Secure the power wand equipment on top of the tank cover.

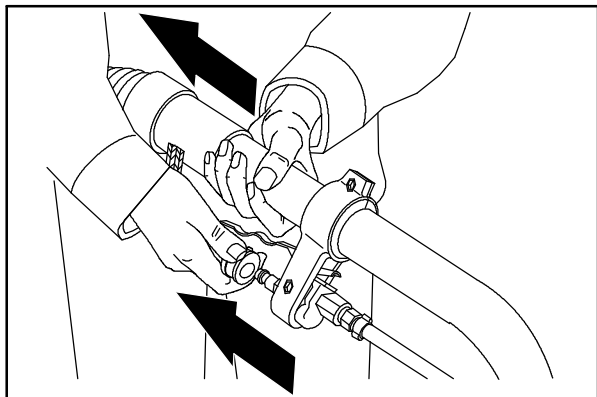

07321

# OPERATION

## MACHINE TROUBLESHOOTING

Problem	Cause	Remedy
Trailing water – poor or no water pickup.	Worn rear squeegee blades.	Rotate or replace squeegee blades.
	Rear squeegee out of adjustment.	Adjust rear squeegee.
	Side squeegees raised.	Lower side squeegees.
	Worn side squeegee blades.	Replace side squeegee blades.
	Side squeegees out of adjustment.	Adjust side squeegees.
	Too much solution flow to floor.	Reduce solution flow to floor.
	Vacuum hose clogged.	Flush vacuum hoses.
	Recovery tank full.	Drain recovery tank.
	Float stuck shutting off vacuum.	Clean float.
	Debris caught on rear squeegee.	Remove debris.
	Foam filling recovery tank.	Empty recovery tank; use less or change detergent.
	Vacuum hose to rear squeegee disconnected or damaged.	Reconnect or replace vacuum hose.
	Vacuum fan to recovery tank hose damaged.	Replace hose.
Vacuum fan will not turn on	Recovery tank full	Drain recovery tank
	Foam filling recovery tank	Empty recovery tank
		Use less or change detergent
		Use a defoamer
	Vacuum fan circuit breaker tripped	Reset circuit breaker
Vacuum fan failure	Contact Tennant service representative	
Little or no solution flow to the floor.	Solution tank empty.	Fill solution tank.
	Solution control linkage broken or out of adjustment.	Replace and/or adjust cable.
	Solution supply lines plugged.	Flush solution supply lines.
	ES™ switch off.	Turn ES™ switch on.
Poor scrubbing performance.	Debris caught on scrub brushes.	Remove debris.
	Improper detergent or brushes used.	Check with TENNANT representative for advice.
	Worn scrub brushes.	Replace scrub brushes.
ES™ system does not fill solution tank.	Clogged solution pump or lines.	Flush ES™ system.
	ES™ float switch(es) stuck.	Clean switch floats of debris.
	Clogged ES™ filter.	Clean filter.
	Water levels too low in tanks.	Add water.





**MAINTENANCE**

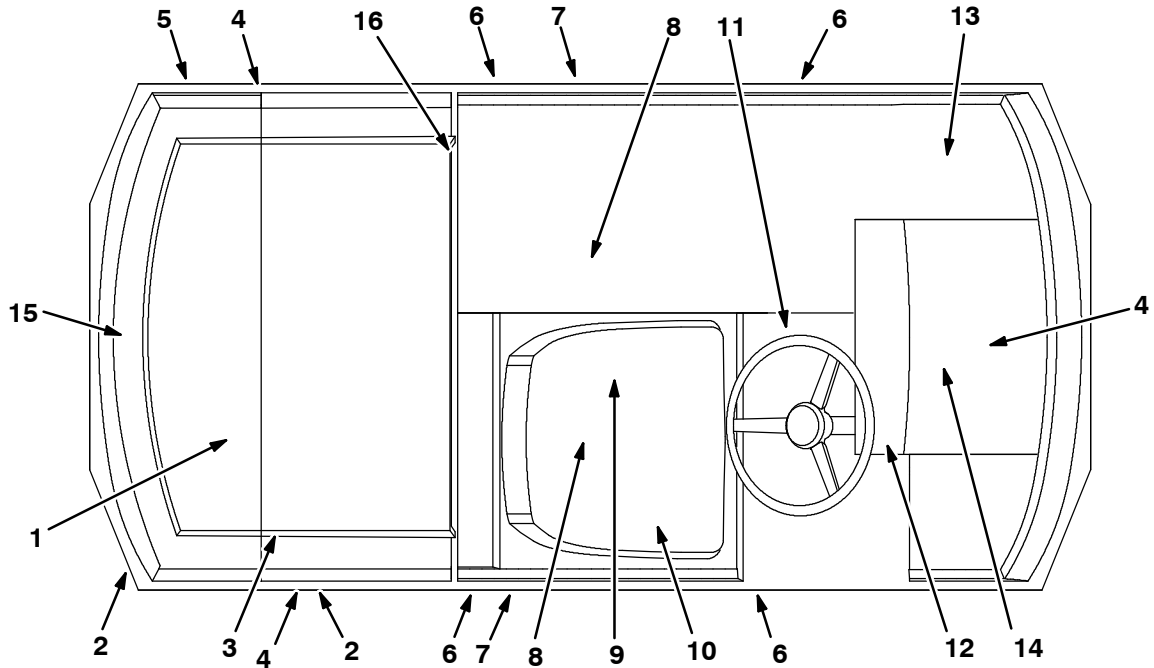

10656

**MAINTENANCE CHART**

Interval	Key	Description	Procedure	Lubricant/ Fluid	No. of Service Points
Daily	5	Rear Squeegee	Check for damage, wear and adjustment	-	1
	7	Side Squeegees	Check for damage and wear	-	2
	8	Scrub brushes	Check for damage and wear	-	2
	3	Recovery tank	Clean	-	1
	3	Recovery tank, ES™ mode	Clean ES™ filter	-	1
	1	Vacuum fan inlet filter	Clean	-	1
	2	Solution tank, ES™ mode	Clean and flush	-	1
	16	Vacuum fan filter	Clean and flush	-	1
	-	Machine	Check for leaks	-	1
50 Hours	10	Scrub head floor skirts	Check for damage and wear and adjust	-	5
	-	Battery	Check electrolyte level	-	1

Interval	Key	Description	Procedure	Lubricant/ Fluid	No. of Service Points
100 Hours	4	Tires	Check for damage	-	3
	14	Propelling gearbox	Check lubricant level	GL	1
	14	Front wheel support bearing	Lubricate	SPL	2
	6	Scrub head parallel arm pivot points	Lubricate	SPL	8(4)
		Steering universal joint	Lubricate	SPL	2
	11	Brakes	Check adjustment	-	1
	15	Rear squeegee caster	Lubricate	SPL	1
500 Hours	13	Vacuum fan motor	Check motor brushes	-	2(3)
	12	Steering gear chain	■ Check tension and lubricate	GL	1
	14	Front wheel	■ Torque wheel nuts	-	1
	6	Scrub head gas spring	Check for wear and operation	-	1
1000 Hours	14	Propelling gearbox	■ Change gear lubricant	GL	1
			■ Change fill-level plug seals	-	1
	9	Scrubbing brush drive motors	Check motor brushes	-	2(3)
	14	Propelling motor	Check motor brushes	-	1

SPL - Special lubricant, Lubriplate EMB grease (Tennant part no. 01433-1)  
 GL - SAE 90 weight gear lubricant

*NOTE: Also check procedures indicated (■) after the first 50-hours of operation.*

## LUBRICATION

### PROPELLING GEARBOX

Check the lubricant level in the propelling gearbox every 100 hours of operation. Change the gear lubricant, and the drain and fill-level plug seals after the first 50 hours of operation, and then every 1000 hours of operation. Use SAE 90 weight gear lubricant.

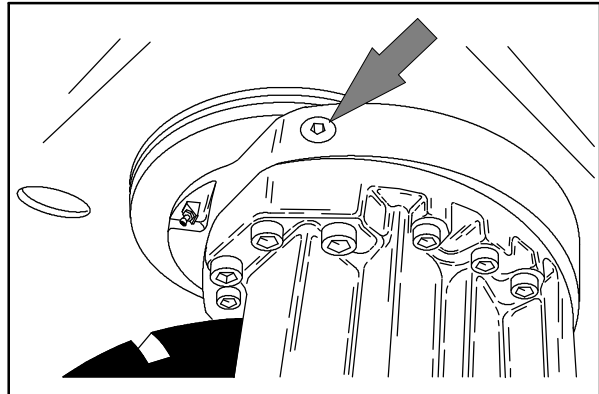

05934

### FRONT WHEEL SUPPORT BEARING

The front wheel support has two grease fittings for the bearing. Raise the machine so the front wheel is off the floor. Fill one of the grease fittings while rotating the gearbox from stop to stop. Fill the second grease fitting while rotating the gearbox back to the original position. The bearing cavity is full when grease comes out of the fittings, or out of the top seal.

Lubricate with Lubriplate EMB grease (Tennant part no. 01433-1) every 100 hours of machine operation, or after steam cleaning the gearbox area.

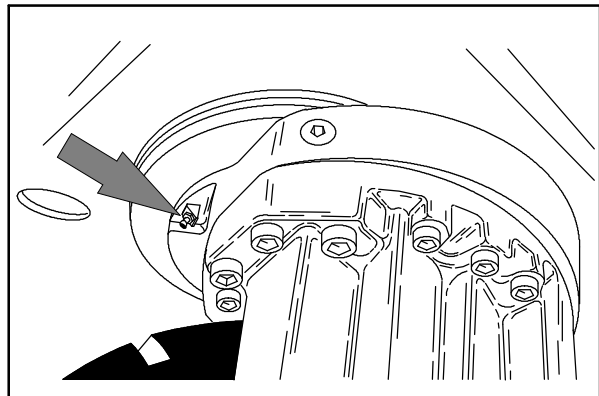

05934

**FOR SAFETY: When servicing machine, block machine tires before jacking machine up.**

**FOR SAFETY: When servicing machine, jack machine up at designated locations only. Block machine up with jack stands.**

### STEERING UNIVERSAL JOINT

The steering universal joint has two grease fittings. Lubricate with Lubriplate EMB grease (Tennant Part No. 01433-1) every 100 hours of operation.

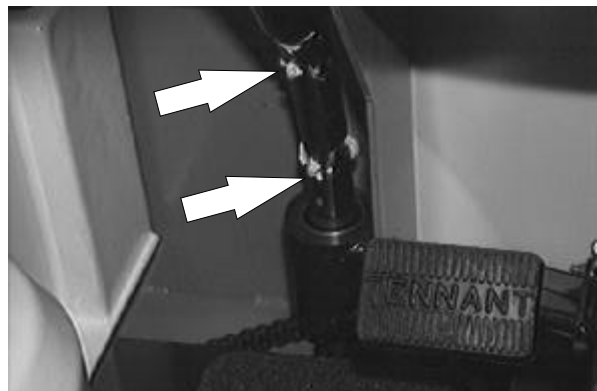

**SCRUB HEAD PARALLEL ARMS**

The scrub head parallel arms have a grease fitting at each of the eight pivot points. Lubricate with Lubriplate EMB grease (Tennant Part No. 01433-1) every 100 hours of operation.

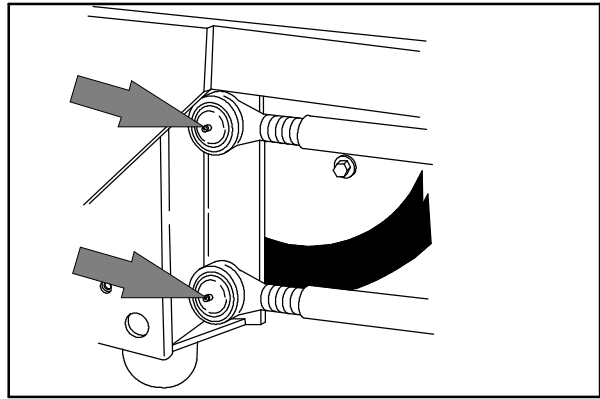

05917

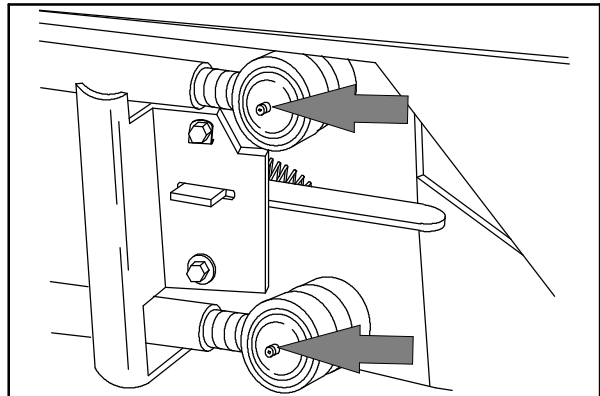

05919

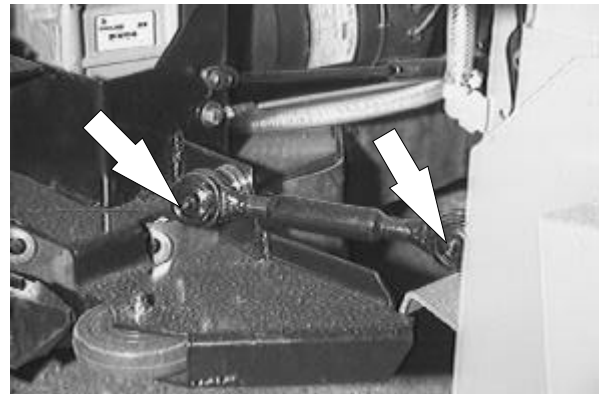

## MAINTENANCE

### REAR SQUEEGEE CASTER

The rear caster has one grease fitting. The caster must be lubricated every 100 hours of operation. Use Lubriplate EMB grease (Tennant part no. 01433-1).

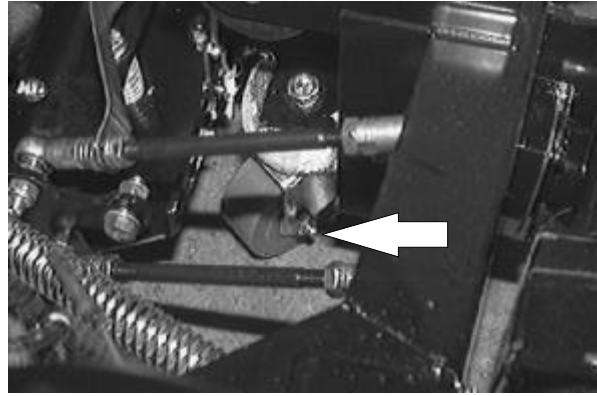

### STEERING GEAR CHAIN

The steering gear chain is located by the foot pedals. Lubricate the chain with SAE 90 weight gear lubricant after 500 hours of operation.



---

## BATTERIES

---

The batteries are unique in that they hold their power for long periods of time. The lifetime of the batteries is limited by the number of charges the batteries receive. To get the most life from the batteries, charge them when all the battery discharge indicator segments shut off (20% charge left). Use an automatic charger with the proper rating for the batteries.

Periodically clean the top surface of the batteries and the terminals, and check for loose connections. Use a strong solution of baking soda and water. Brush the solution sparingly over the battery tops, terminals, and cable clamps. Do not allow any baking soda solution to enter the batteries. Use a wire brush to clean the terminal posts and the cable connectors. After cleaning, apply a coating of clear battery post protectant to the terminals and the cable connectors. Keep the tops of the batteries clean and dry.

Keep all metallic objects off the top of the batteries, which may cause a short circuit. Replace any worn or damaged wires.

Check the electrolyte level in each battery after charging, and every 50 hours of operation. Never add acid to the batteries, only distilled water. Always keep the battery caps on, except when adding water or taking hydrometer readings.

Measuring the specific gravity, using a hydrometer, is a way to determine the charge level and condition of the batteries. If one or more of the battery cells test lower than the other battery cells (0.050 or more), the cell is damaged, shorted, or is about to fail.

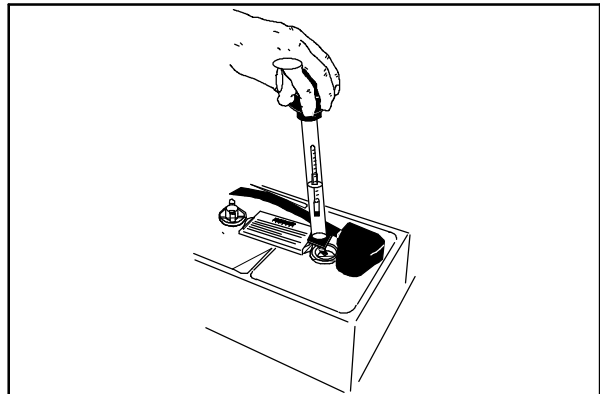

04380

## MAINTENANCE

*NOTE: Do not take readings immediately after adding distilled water. If the water and acid are not thoroughly mixed, the readings may not be accurate. Check the hydrometer readings against the following chart to determine the remaining battery charge level:*

SPECIFIC GRAVITY at 27° C (80° F)	BATTERY CHARGE
1.290	100% Charged
1.252	75% Charged
1.200	50% Charged
1.177	25% Charged
1.140	Discharged

*NOTE: If the readings are taken when the battery electrolyte is any temperature other than 27° C (80° F), the reading must be temperature corrected. Add or subtract to the specific gravity reading 0.004, 4 points, for each 6° C (10° F) above or below 27° C (80° F).*

### CHARGING THE BATTERIES

1. Drive the machine to a flat, dry surface in a well-ventilated area.
2. Turn the machine power off and set the parking brake.

**FOR SAFETY: Before leaving or servicing machine; stop on level surface, turn off machine.**

3. Open the machine cover.

**⚠ WARNING: Batteries emit hydrogen gas. Explosion or fire can result. Keep sparks and open flame away. Keep covers open when charging.**

4. Remove the seat support.

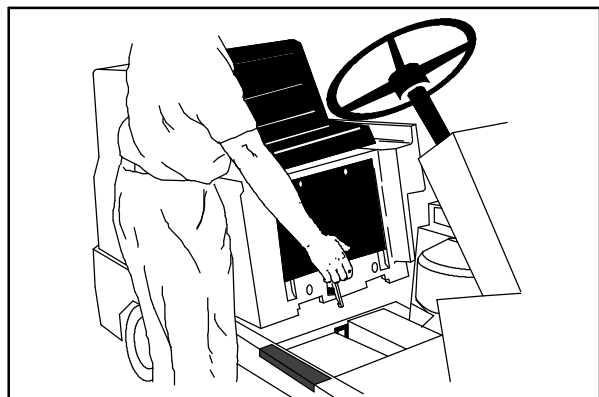

05916



5. Check the water level in all the battery cells. If the level is low, add just enough distilled water to cover the plates. **DO NOT OVERFILL.** The batteries can overflow during charging due to expansion.

*NOTE: Make sure the battery caps are in place while charging.*

**FOR SAFETY: When maintaining or servicing machine, avoid contact with battery acid.**

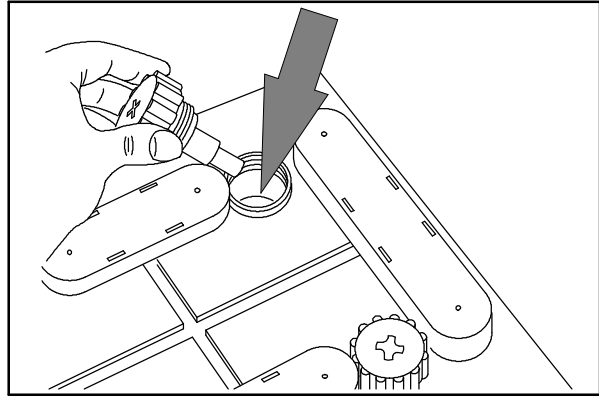

08247

6. Unplug the battery connector from the machine connector.

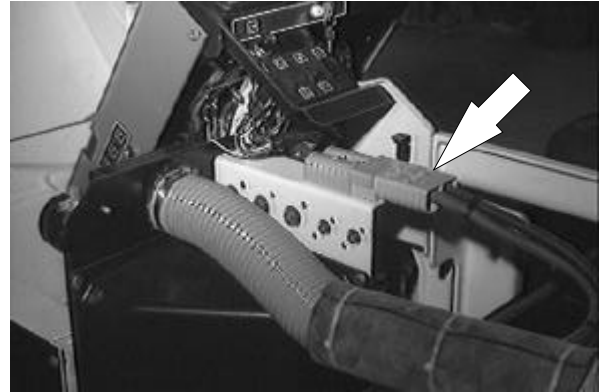

7. Plug the charger connector into the battery connector.

8. Plug the battery charger into the wall outlet.

*NOTE: If the red "ABNORMAL CYCLE" lamp lights when the TENNANT charger is plugged into a wall outlet, the charger can not charge the battery and there is something wrong with the battery.*

9. The Tennant charger will start automatically. When the batteries are fully charged, the Tennant charger will automatically turn off.

*NOTE: Use a charger with the proper rating for the batteries to prevent damage to the batteries or reduce the battery life.*

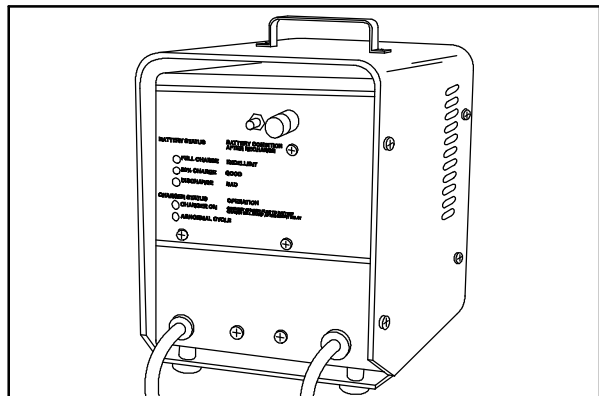

07224

*NOTE: If the charger needs to be disconnected from the machine before the batteries are fully charged and the charger has not automatically shut off, turn off the charger before disconnecting it.*

10. After the charger has turned off, unplug the charger from the wall outlet.

11. Unplug the charger connector from the battery connector on the machine.

**FOR SAFETY: When maintaining or servicing machine, avoid contact with battery acid.**

## MAINTENANCE

12. Reconnect the battery connector to the machine connector.
13. Check the electrolyte level in each battery cell. Add just enough distilled water to bring the electrolyte level up to the bottom of the fill rings.
14. Replace the seat support.
15. Close the machine cover.

## CONTROL PANEL

The control panel can be used to run a self-diagnostic test of the machine electrical components and system. When the self-diagnostic test is running, motors and actuators on the machine will activate.

**FOR SAFETY: When servicing machine, avoid moving parts. Do not wear loose jackets, shirts, or sleeves.**

1. Turn the machine power off.
2. While pressing the squeegee switch, turn the machine power on. Continue pressing the squeegee switch a few seconds, then release the switch.
3. While the diagnostic is running, the machine systems will activate as follows:
  - The brushes and squeegee raise.
  - The vacuum fan starts and the squeegee lowers. The squeegee raises and the vacuum fan shuts off.
  - The scrub head lowers and moves out to the edge scrub position. The scrub head moves back in again and raises.
  - The brushes turn on and off.
  - The solution tank auto-fill valve turns on and off.
  - The ES™ pump turns on and off, if the machine has the ES™ option.
  - The vacuum fan starts and shuts off.
  - The brushes turn on and off.

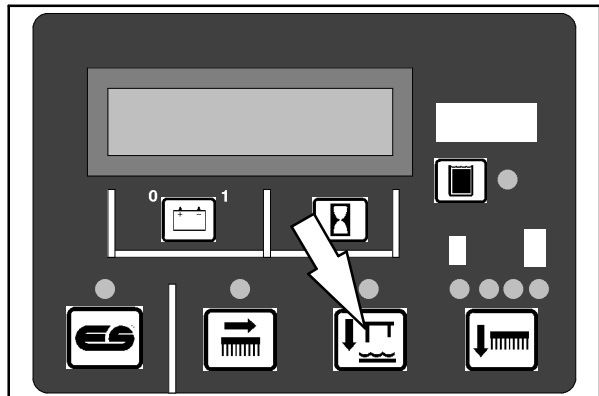

10734

- The recovery tank auto-fill valve turns on and off.
4. If the electrical system passes the self-diagnostic test, an OK message will appear on the control panel display.

If the self-diagnostic test finds an error in the system, an error message will appear on the control panel display. Note the error message displayed, and contact the service personnel.

5. Turn off the diagnostic by turning off the machine power.

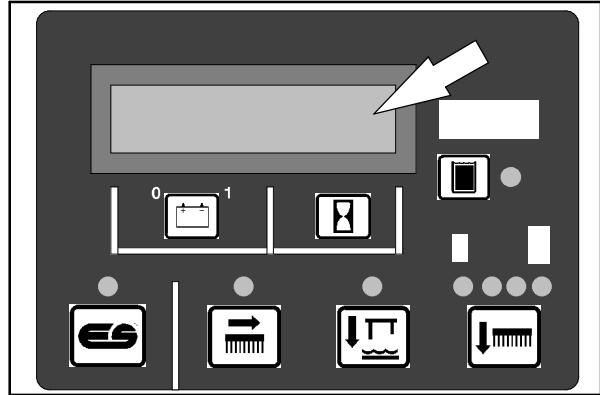

10734

---

## **ELECTRIC MOTORS**

---

The carbon brushes on the vacuum fan motors should be inspected every 500 hours of machine operation. The brush drive motors and propelling motor should be inspected every 1000 hours of operation.

---

## **PROPELLING CIRCUIT**

---

The propelling circuit is a transistorized controller. It controls the forward and reverse speed of the machine and is located in the controller panel. The circuit cannot be serviced by the user - only trained personnel should be allowed to work on it. Do not steam clean or spray the panel with water because the electrical system may be damaged.

*NOTE: A static discharge grounding strap should be used when servicing the electronic circuitry.*

---

## **SCRUB HEAD**

---

The machine can be equipped with either a MaxPro™ 1000 or MaxPro™ 1200 scrub head. The MaxPro™ 1000 is the standard two disk brush scrub head. The optional MaxPro™ 1200 is a three disk brush scrub head. The scrub head floor skirts control water spray from the brushes.

### SCRUB HEAD FLOOR SKIRTS

The skirts are located in front and rear of the scrub head. Check these skirts for wear and damage every 50 hours of operation.

The skirts should clear the floor by 0 to 6 mm (0 to 0.25 in) when the scrub head is down. Check the floor skirt adjustment every 50 hours of operation.

The rear scrub head floor skirts can be adjusted by pulling the skirt up or down without loosening the retainer hardware.

The front scrub head floor skirts need the retainer hardware loosened to move the skirt up or down. Tighten the retainer hardware enough to hold the skirt firmly in place.

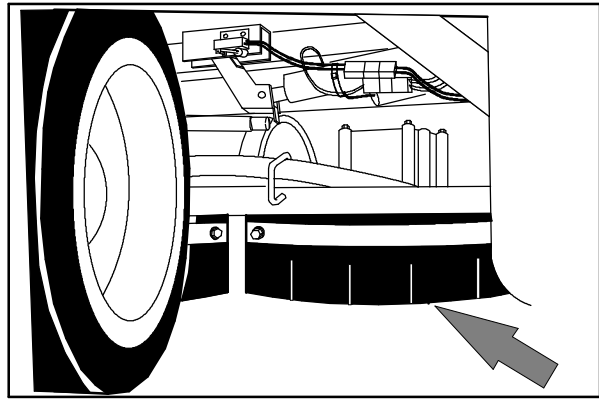

05937

### SCRUB HEAD GAS SPRING

Check the scrub head gas spring for wear and proper operation every 500 hours of operation.

### SCRUB HEAD ADJUSTMENTS

The scrub head is factory adjusted, and the measurements should not be changed unless scrub head parts are damaged or are replaced.

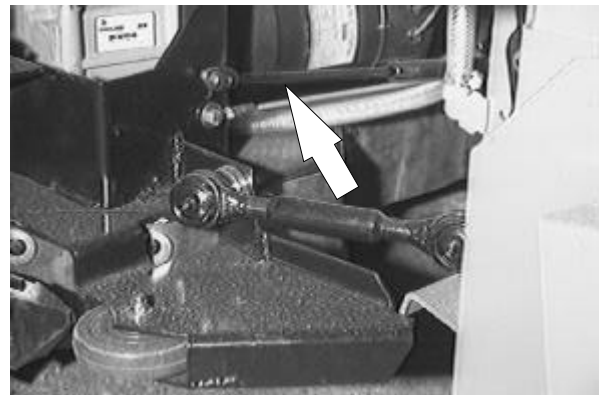

---

### SCRUB BRUSHES

---

Check the scrub brushes daily for wire or string tangled around the brush or brush drive hub. Also check the brushes for any damage and wear.

The scrub brushes should be replaced if large amounts of bristles are missing, or if the remaining bristles' length is less than 6 mm (0.25 in).

*NOTE: Be sure to replace brushes in sets. Otherwise one brush will be more aggressive than the other.*

Cleaning pads must be placed on pad drives before they are ready to use. The cleaning pad is held in place by a pad holder.

Cleaning pads need to be cleaned immediately after using with soap and water. Do not wash the pads with a pressure washer. Hang dry pads, or lie flat to dry.

**REPLACING THE SCRUB BRUSHES**

1. Raise the scrub head.
2. Turn the machine power off and set the parking brake.

**FOR SAFETY: Before leaving or servicing machine; stop on level surface, set parking brake, turn off machine and remove key.**

3. Push back on the side squeegee release lever. Pull up on the side squeegee assembly and remove it from the scrub head. Repeat for the other side of the scrub head.

*NOTE: Remove the suction hose from the right-hand side squeegee assembly on the MaxPro™ 1200 scrub head.*

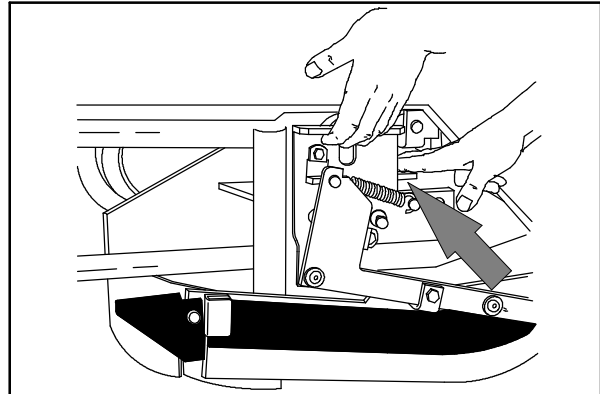

05938

4. Press the brush spring clip ends together with your thumb and index finger to remove the scrub brush. Repeat for the other brush or brushes.
5. For the MaxPro™ 1200 scrub head, start with the center brush. Slide the new scrub brush under the scrub brush drive assembly.
6. Line up the scrub brush drive socket with the drive plug.
7. Lift and snap the scrub brush onto the drive plug.
8. Check to make sure the brush is securely mounted on the brush hub.
9. Push back on the side squeegee release lever. Slide the side squeegee assembly onto the scrub head. Repeat on the other side of the scrub head.

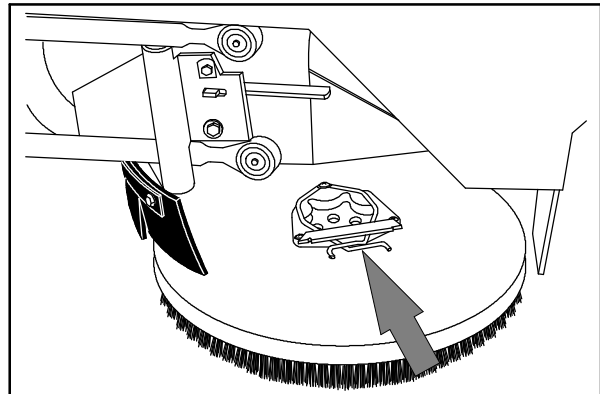

05939

*NOTE: Reconnect the suction hose to the right-hand side squeegee assembly on the MaxPro™ 1200 scrub head.*

10. Check the scrub head front and rear skirt adjustments as described in *SCRUB HEAD FLOOR SKIRTS*.

## SOLUTION SYSTEM

### SOLUTION VALVE

The solution valve controls the flow of solution to the scrub brushes. The valve linkage should provide the valve with fully open to fully closed positions.

The solution control cable can be adjusted at the solution lever or valve ends of the cable. To adjust the cable at the solution lever end, open the machine cover. To adjust the cable at the solution valve end of the cable, locate the valve by the scrub head. Adjust the cable with the valve in the off position.

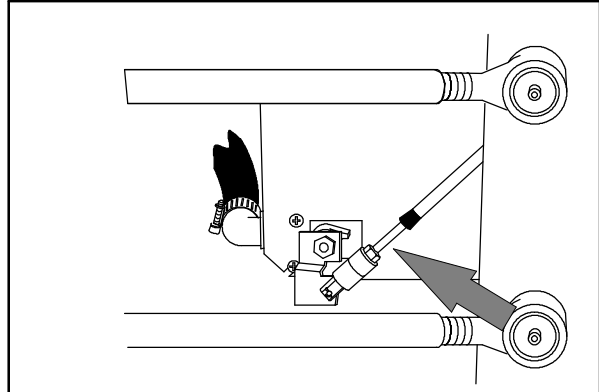

05941

The solution lever has two mounting holes for the solution cable clevis. In the factory, the cable is mounted on the inside hole. The cable clevis can be moved to the outside hole for greater solution flow to the floor. This mounting position would be for rough floor conditions only.

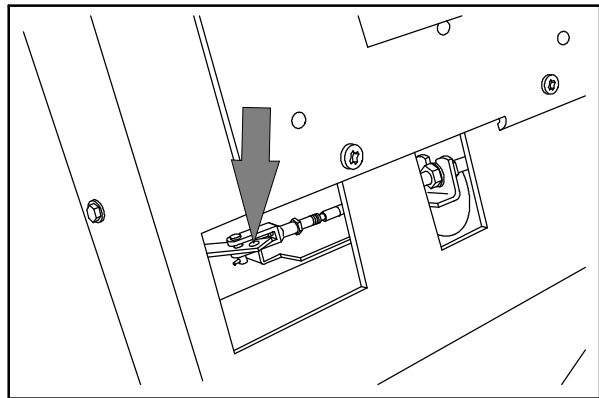

06011

### RECOVERY TANK

The recovery tank stores recovered solution.

The recovery tank should be drained and cleaned daily, after the solution tank is empty, whenever the float stops the vacuum fan, or the recovery tank full indicator lights. See *DRAINING AND CLEANING THE TANKS* section of this manual.

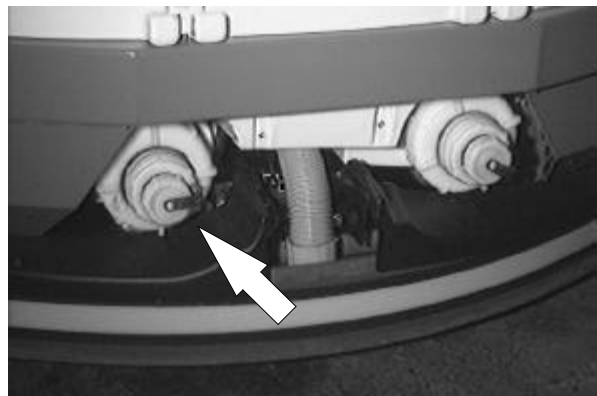

For machines serial number 004868 and above, the vacuum fan filter should be cleaned daily. See *DRAINING AND CLEANING THE TANKS* section of this manual.

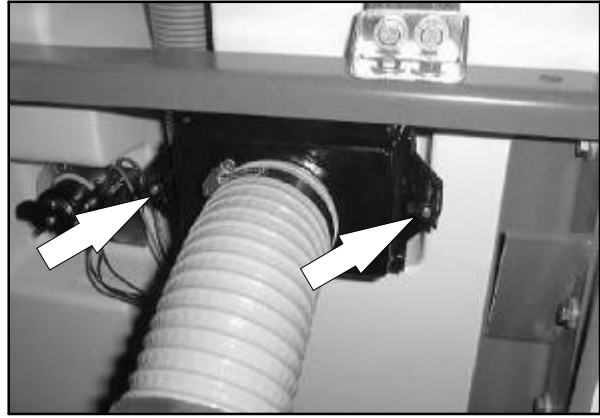

ES™ option: The ES™ filter should be cleaned daily.

The outside of the tank can be cleaned with vinyl cleaner.

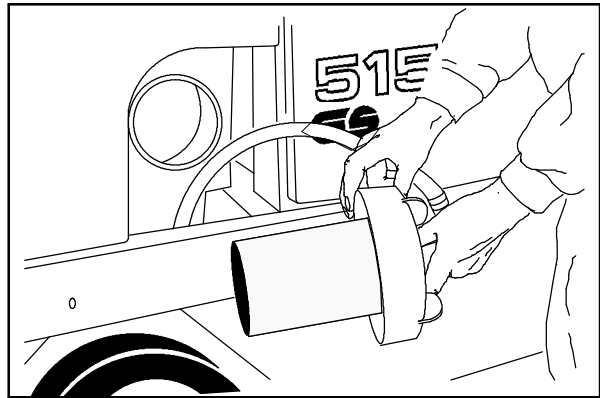

10916

**SOLUTION TANK**

The solution tank stores the cleaning solution.

The solution tank does not require regular maintenance. If deposits form on the bottom of the tank, rinse the tank with a strong blast of warm water. The tank can be flushed through the fill opening. Drain the tank with the solution tank drain hose.

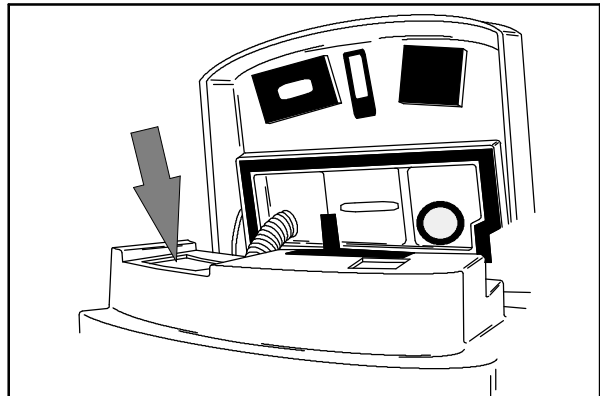

05921

ES™ option: The solution tank should be drained and cleaned daily.

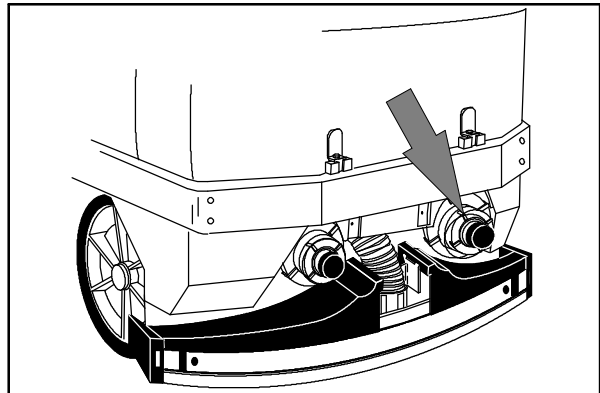

05940

## SQUEEGEES

---

As the machine travels forward the squeegees wipe the dirty solution off the floor, which is then picked up and drawn into the recovery tank. The front blade channels the water, and the rear blade wipes the floor.

The side squeegees control water spray and channel water into the path of the rear squeegee.

### REAR SQUEEGEE

Check the squeegee blades for damage and wear daily. Rotate or replace either of the squeegee blades if the leading edge is torn or worn half-way through the thickness of the blade.

The squeegee can be adjusted for leveling and deflection. The deflection and leveling of the squeegee blades should be checked daily, or when scrubbing a different type of floor.

### LEVELING THE REAR SQUEEGEE

Leveling of the squeegee assures even contact the length of the squeegee blade with the surface being scrubbed. Make sure this adjustment is done on an even, level floor.

1. Turn the machine power on.
2. Lower the squeegee.
3. Set the machine parking brake while the driving machine slowly forward, and turn the machine power off.

**FOR SAFETY: Before leaving or servicing machine; stop on level surface, set parking brake, turn off machine and remove key.**

4. Look at the deflection of the squeegee blade, over the full length of the squeegee blade.



5. If the deflection is not the same over the full length of the blade, adjust the deflection by turning the leveling adjustment screw.

Turn the leveling adjustment screw clockwise to decrease the deflection at the ends of the squeegee blade.

Turn the leveling adjustment screw counter-clockwise to increase the deflection at the ends of the squeegee blade.

6. Release the parking brake and drive the machine forward again with the squeegee down to check the squeegee blade deflection.
7. Readjust the squeegee level if necessary.

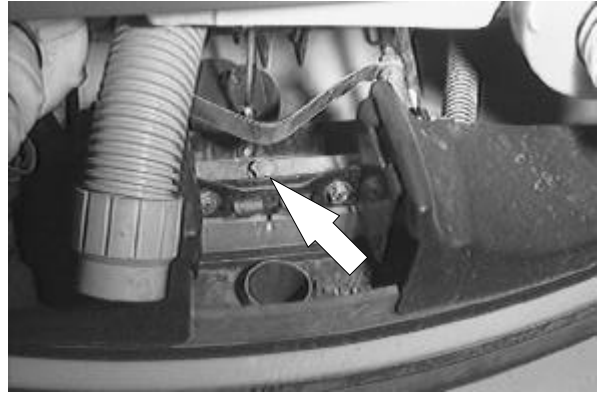

### ADJUSTING REAR SQUEEGEE BLADE DEFLECTION

Deflection is the amount of curl the squeegee blade has when the machine moves forward with the squeegee lowered to the floor. The best deflection is when the squeegee wipes the floor just dry with a minimum amount of deflection.

1. Turn the machine power on.
2. Lower the squeegee.
3. Set the machine parking brake while driving the machine slowly forward, and turn the machine power off.

**FOR SAFETY: Before leaving or servicing machine; stop on level surface, set parking brake, turn off machine and remove key.**

4. Look at the deflection of the squeegee blade. The correct amount of deflection is 15 to 20 mm (0.50 to 0.75 in).

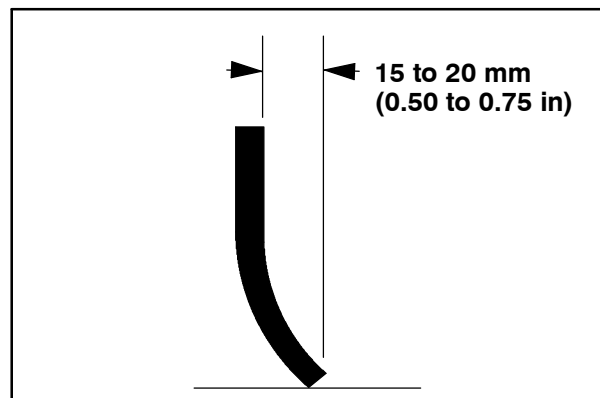

03719

5. To adjust the amount of deflection, loosen the caster jam nut. Turn the caster shaft using the flats.

Turn the shaft clockwise to decrease the blade deflection. Turn the shaft counter-clockwise to increase blade deflection. Tighten the jam nut.

6. Release the parking brake and drive the machine forward again to check the squeegee blade deflection.
7. Readjust the squeegee blade deflection if necessary.

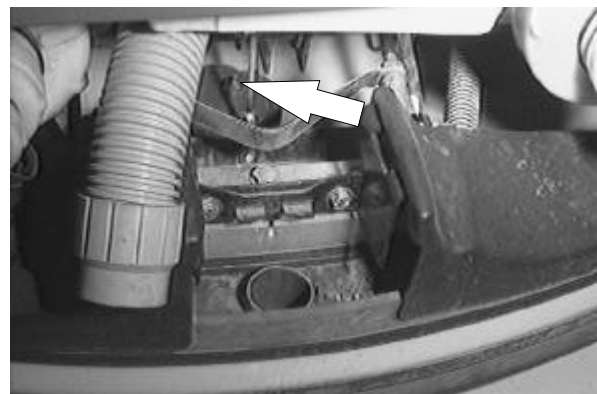

**SIDE SQUEEGEE ADJUSTMENT**

The side squeegee has one adjustment; height. To change the height adjustment, disconnect the squeegee spring from the clevis pin and move the clevis pin to a different hole location. The factory setting is in the middle hole location.

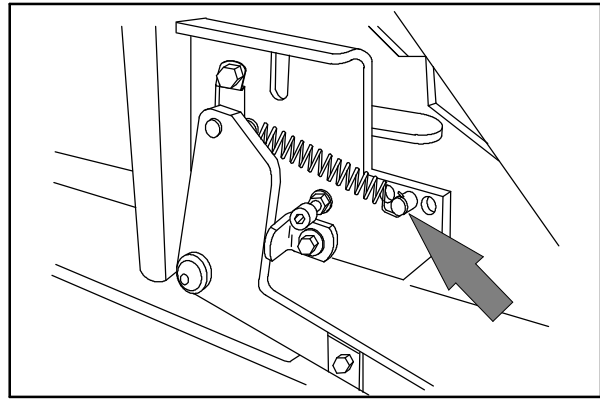

05918

**SQUEEGEE BLADES**

The rear squeegee assembly channels water into the vacuum fan suction. The front blade channels the water, and the rear blade wipes the floor.

The side squeegees control water spray and channel water into the path of the rear squeegee.

Replace any worn or damaged squeegee blades.

**REAR SQUEEGEE BLADES**

Check the squeegee blades for damage and wear daily. Rotate or replace either of the squeegee blades if the leading edge is torn or worn half-way through the thickness of the blade.

The squeegee has two squeegee blades, the front and rear. Each blade has four wiping edges. To use them all, start with one wiping edge. To use the next wiping edge, rotate the blade end-for-end. To use the next wiping edge, rotate the top edges down, bottom edges up. To use the last edge, rotate the blade end-for-end.

**REPLACING OR ROTATING THE REAR SQUEEGEE BLADES**

1. Make sure the squeegee is raised off the floor.
2. Turn the machine power off and set the parking brake.

**FOR SAFETY: Before leaving or servicing machine; stop on level surface, turn off machine.**

## MAINTENANCE

3. Remove the ringed pin, deflector, gasket, retainer bracket, and retainer strip from the end of the squeegee.
4. Pull off the squeegee assembly cover.
5. Pull the squeegee blade off the squeegee frame.
6. Replace or rotate the squeegee to allow a new edge to face the front of the machine.
7. Slide the squeegee blade onto the squeegee frame.

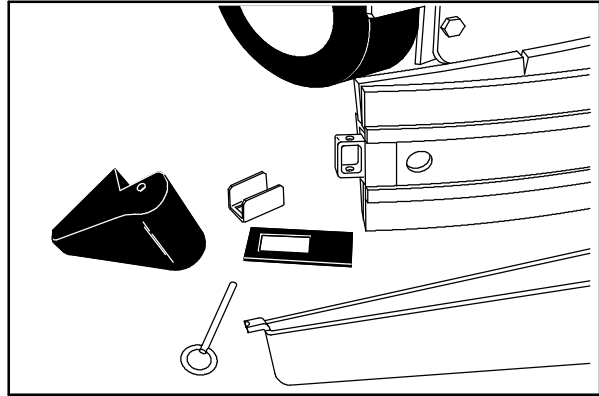

05943

*NOTE: Lubricating the squeegee frame where the squeegee makes contact will make it easier to install the squeegee blade.*

8. Slip the retainer strip into the squeegee blade. Slip the retainer bracket on the end of the squeegee frame. Place the squeegee gasket on the end of the squeegee frame with the long end down and back.
9. Replace the squeegee assembly cover.
10. Replace the deflector and the ringed pin.
11. Adjust the rear squeegee as described in *LEVELING THE REAR SQUEEGEE* and *ADJUSTING REAR SQUEEGEE BLADE DEFLECTION*.

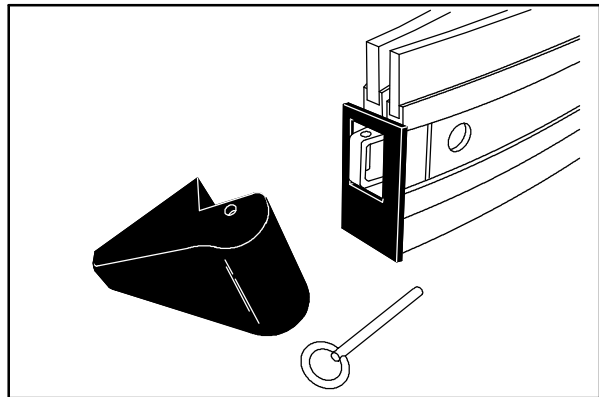

05945

### SIDE SQUEEGEES BLADES

The side squeegees control water spray and channel water into the path of the rear squeegee. Check the side squeegees for damage and wear daily.

Replace the side squeegee blades whenever they become damaged or lose their shape or resiliency. Replace the squeegee deflectors whenever they become worn.

**REPLACING SIDE SQUEEGEE BLADES**

1. Raise the scrub head.
2. Turn the machine power off and set the parking brake.

**FOR SAFETY: Before leaving or servicing machine; stop on level surface, set parking brake, turn off machine and remove key.**

3. Remove the cotter pin, clevis pin, deflector, and the retainer bracket from the front of the side squeegee.
4. Pull the squeegee blade off the front of the squeegee frame.

*NOTE: On the MaxPro™ 1200 scrub head, check the inside squeegee on the right side of the scrub head for damage and wear. Replace if necessary.*

5. Slide the new squeegee blade onto the frame.

*NOTE: Lubricating the squeegee frame where the squeegee makes contact will make it easier to install the squeegee blade.*

6. Replace the retainer bracket, deflector, clevis pin, and cotter pin.
7. Repeat for the side squeegee on the other side of the scrub head.

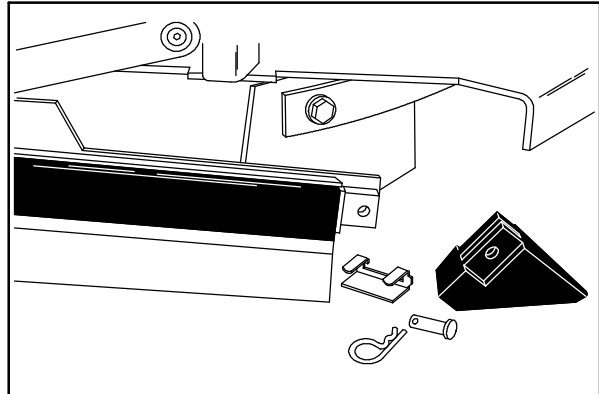

05942

## CHAINS

### STEERING GEAR CHAIN

The steering gear chain tension should be checked after the first 50 hours of operation and every 500 hours there after. The deflection should be 3 to 6 mm (0.12 to 0.25 in) between the steering sprocket and the idler sprocket when the steering wheel is turned the tightest position either direction.



### STATIC DRAG CHAIN

A static drag chain prevents the buildup of static electricity in the machine. The chain is attached to the transaxle.

Make sure the chain is always touching the floor.

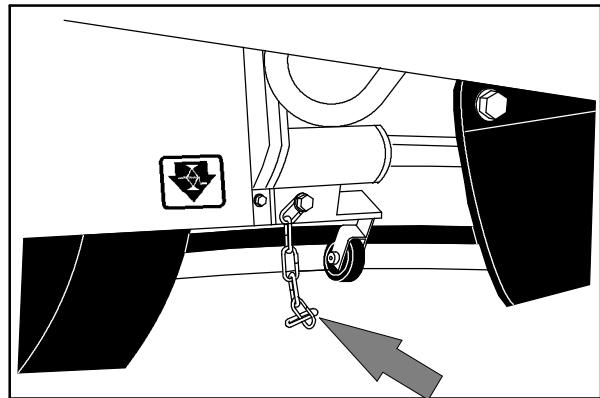

05936

**BRAKES AND TIRES**

**BRAKES**

The foot brake and the parking brake operate the linkage that controls the brakes on the rear wheels.

The parking brake should be adjusted after every 100 hour of operation or whenever it becomes very easy to engage.

To adjust the parking brake, turn the knurled knob on the end of the parking brake lever counter-clockwise.

The foot pedal should not travel more than 25 mm (1 in) to engage the brake. Check the brake adjustment after every 100 hours of operation.

Park the machine on a level surface. Turn the machine power off, and block the machine tires.

Loosen the adjustment nuts. Adjust the brake cable with one nut and lock in place with the other nut.

Adjust the brake cable so that the brake pedal travels no more than 25 mm (1 in) to fully engage the brakes. Readjust the brake cable if necessary.

Remove the blocks from the machine tires.

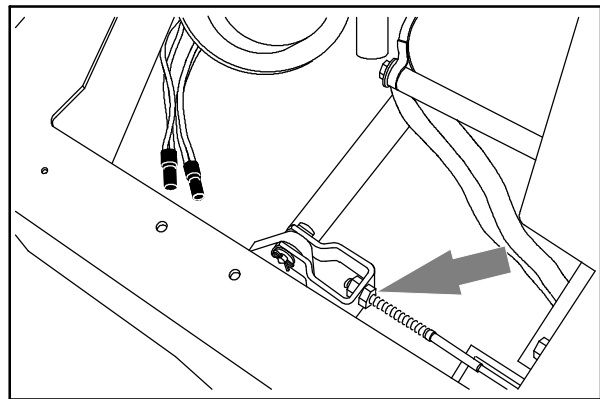

05947

**TIRES**

All the machine tires are solid. Check the tires for wear every 100 hours of operations.

**FRONT WHEEL**

Torque the front wheel nuts to 122 to 155 Nm (90 to 110 ft lb) after the first 50 hours of operation, and every 500 hours of operation.

---

### PUSHING, TOWING, AND TRANSPORTING THE MACHINE

---

#### PUSHING OR TOWING THE MACHINE

If the machine becomes disabled, it can be pushed from the front or rear, but tow it only from the rear.

Only push or tow the machine for a *very short distance* and do not exceed 3.2 kp/h (2 mph). It is NOT intended to be pushed or towed for a long distance or at a high speed.

**ATTENTION! Do not push or tow machine for a long distance or damage may occur to the propelling system.**



**TRANSPORTING THE MACHINE**

1. Position the rear of the machine at the loading edge of the truck or trailer.
2. If the loading surface is not horizontal or is higher than 380 mm (15 in) from the ground, use a winch to load machine.

If the loading surface is horizontal AND is 380 mm (15 in) or less from the ground, the machine may be driven onto the truck or trailer.

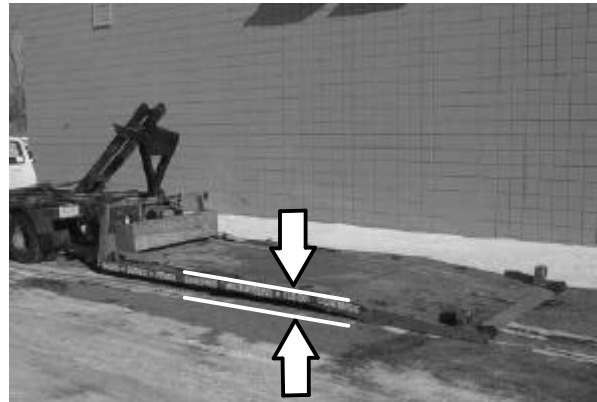

3. To winch the machine onto the truck or trailer, attach the winching chains at the bottom of the rear bumper.

If the machine has the optional rear tie down brackets, attach the winching chains to them.



**FOR SAFETY: When loading machine onto truck or trailer, use winch. Do not drive the machine onto the truck or trailer unless the loading surface is horizontal AND is 380 mm (15 in) or less from the ground.**

4. Position the machine onto the truck or trailer as far as possible. If the machine starts to veer off the centerline of the truck or trailer, stop and turn the steering wheel to center the machine.

## MAINTENANCE

5. Set the parking brake and block the machine tires. Tie down the machine to the truck or trailer before transporting.

The tie down locations are at each corner of the machine fram.

If the machine has the optional tie down brackets, attach the winching chains to them.



6. If the loading surface is not horizontal or is higher than 380 mm (15 in) from the ground, use a winch to unload machine.

If the loading surface is horizontal AND is 380 mm (15 in) or less from the ground, the machine may be driven off the truck or trailer.

**FOR SAFETY: When unloading machine off truck or trailer, use winch. Do not drive the machine off the truck or trailer unless the loading surface is horizontal AND 380 mm (15 in) or less from the ground.**

**MACHINE JACKING**

You can jack up the machine for service at the designated locations. Use a jack of adequate capacity and in good working condition. Always stop the machine on a flat, level surface and block the tires before jacking up the machine.

The front jacking location is the main frame just in front of the scrub head.

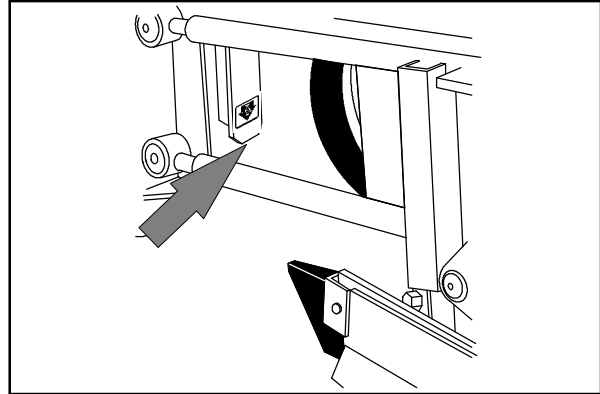

05931

The rear jacking locations are the main frame just in front of the rear tires.

Always stop the machine on a flat level surface and block the machine tires before jacking up the machine.

**FOR SAFETY: When servicing machine, block machine tires before jacking machine up.**

**FOR SAFETY: When servicing machine, jack machine up at designated locations only. Block machine up with jack stands.**

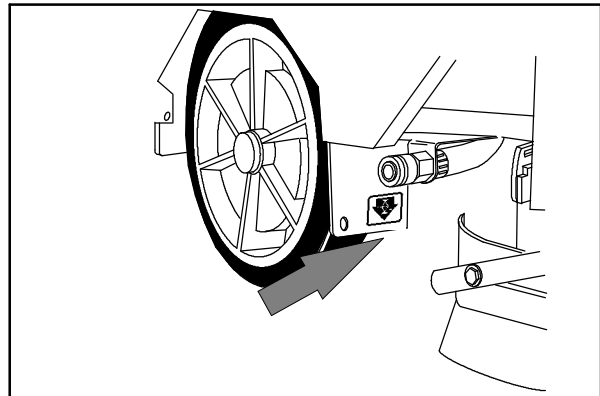

05922

## STORAGE INFORMATION

---

The following steps should be taken when storing the machine for extended periods of time.

1. Drain and clean the solution and recovery tanks.  
  
ES™ machines: Run clean water through the solution system and the ES™ solution pump.
2. Raise the rear squeegee and the scrub head.
3. Park the machine in a cool, dry area.
4. Remove the batteries, or charge them after every three months.

**SPECIFICATIONS**

**GENERAL MACHINE DIMENSIONS/CAPACITIES**

Item	Dimension/capacity
Length	2110 mm (83 in)
Width, frame	1070 mm (42 in)
Width, rear squeegee	1210 mm (47.5 in)
Width with MaxPro™ 1200 scrub head option	1295 mm (51 in)
Height	1450 mm (57 in)
Height with overhead guard option	2035 mm (80 in)
Scrub brush diameter	510 mm (20 in)
Scrubbing path width	1015 mm (40 in)
Solution tank capacity	210 L (55 gal)
Recovery tank capacity	190 L (50 gal)
Tank capacity with ES™ option	340 L (90 gal)
Propelling gear box 90 weight gear lubricant capacity	2.6 L (2.7 qt)
GVWR	2087 kg (4600 lb)

**GENERAL MACHINE PERFORMANCE**

Item	Measure
Maximum forward speed	8 km/h (5mph)
Maximum reverse speed	4.8 km/h (3mph)
Aisle turnaround width	2290 mm (90 in)
Maximum rated climb and descent angle with empty tanks	8.5°
Maximum rated climb and descent angle with full tanks	6°

## SPECIFICATIONS

### POWER TYPE

Type	Quantity	Volts	Ah Rating	Weight
Batteries	1	36	380 @ 6 hr rate	436 kg (960 lb)
	1	36	420 @ 6 hr rate	585 kg (1290 lb)
	1	36	690 @ 6 hr rate	850 kg (1875 lb)

Type	Use	VDC	Kw (hp)
Electric Motors	Scrub brush	36	0.75 (1)
	Heavy duty scrub brush	36	1.12 (1.5)
	Vacuum fan	36	0.63 (0.85)
	Propelling	36	2.2 (3)

Type	VDC	amp	Hz	Phase	VAC
Chargers	36	120	60	1	208-240-480
	36	120	60	3	208-240-480
	36	120	50	1	208-240-480
	36	120	50	3	208-240-480
	36	75	50	1	208-240-480
	36	75	60	1	208-240-480
	36	75	60	3	208-240-480
	36	50	60	1	240
	36	50	50	1	230
	36	45	50 and 60	1	200

### STEERING

Type	Power source	Emergency steering
Front wheel controlled, universal joint to gear and chain	Manual	Manual

### BRAKING SYSTEM

Type	Operation
Service brakes	Mechanical drum brakes (2), one per rear wheel, cable actuated
Parking brake	Utilizes service brakes, cable actuated

### TIRES

Location	Type	Size
Front (1)	Solid	16.25 x 6
Rear (2)	Solid	16 x 3.5

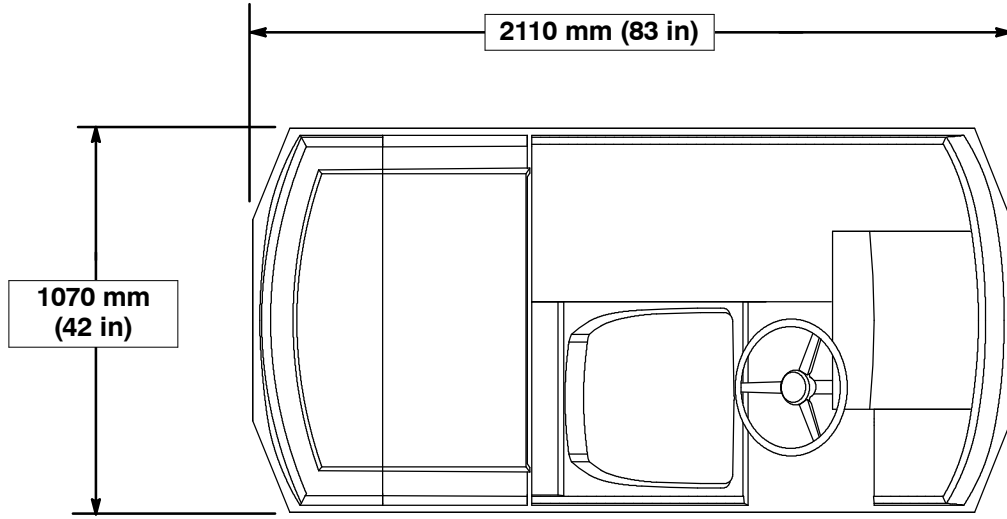

**TOP VIEW**

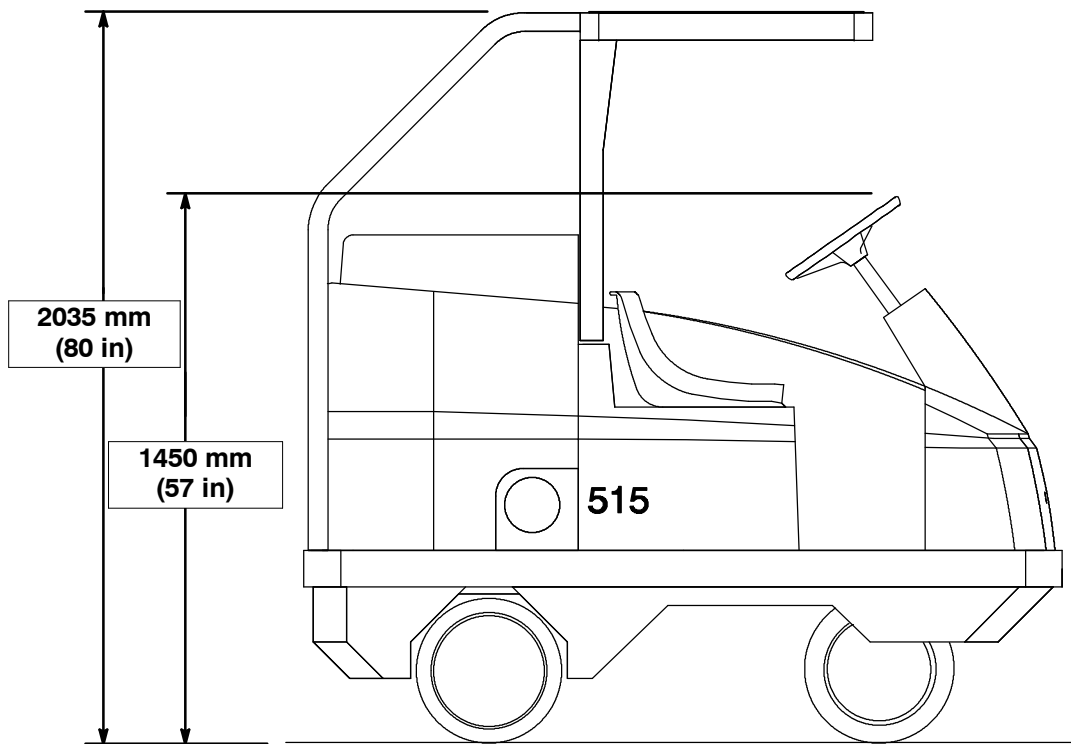

**SIDE VIEW**

**MACHINE DIMENSIONS**

10656

**INDEX****A**

Adjusting rear squeegee blade deflection, 64  
Adjustments  
    Parking brake, 69  
    Service brakes, 69  
Aisle turn, 75  
Adjustments, Steering gear chain, 68

**B**

Batteries, 53–56  
    Charge level, 35  
    Charger specifications, 76  
    Charging, 54–56  
    Discharge indicator, 11  
    Maintenance, 53  
    Specifications, 76  
Battery charge level, 35  
Battery discharge indicator, 11  
Brake pedal, 9  
Brakes, 69  
    Parking, 17  
Braking system, Specifications, 76  
Brush, 35  
Brushes  
    Scrub, 58  
    Scrubbing, 25  
Button, Horn, 16

**C**

Capacities, 75  
Chain, Steering gear, 52  
Chains, 68  
    Static drag, 68  
    Steering gear, 68  
Changing message display language, 13  
Circuit breakers, 18  
Control panel, 15  
    Battery discharge indicator, 11  
    Changing message display language, 13  
    Edge scrub switch, 14  
    ES™ switch, 14  
    Hourmeter, 11  
    Message display, 12  
    Operating lights switch, 16  
    Rear squeegee switch, 14  
    Recovery tank full indicator, 13

Controls, 8  
    Battery discharge indicator, 11  
    Brake pedal, 9  
    Circuit breakers, 18  
    Control panel message display, 12  
    Directional pedal, 9  
    Edge scrub, 14  
    ES™ switch, 14  
    Horn button, 16  
    Hourmeter, 11  
    On-off key switch, 16  
    Operating lights switch, 16  
    Power wand switch, 17  
    Rear squeegee switch, 14  
    Recovery tank full indicator, 13  
    Scrub switch, 15  
    Solution flow lever, 10  
    Steering wheel, 10

**D**

Dimensions, 75  
Directional pedal, 9  
Double scrubbing, 28  
Draining and cleaning the tanks, 31–33, 36

**E**

Edge scrub switch, 14  
Electric motors, 57, 76  
Electrical  
    Batteries, 53–56  
    Charging batteries, 54–56  
    Circuit breakers, 18  
Electronics, Propelling circuit, 57  
ES™  
    Auto-fill, 24  
    Draining and cleaning tanks, 36  
    Filling the tanks, 22–24  
ES™ switch, 14

**F**

Filling the tanks, 22–24  
Front wheel  
    Support bearing, 50  
    Torque, 69  
Front wheel support bearing, 50



**H**

Hazard light switch, 16  
 Horn button, 16  
 Hoses, 36  
   Recovery tank drain, 19  
   Solution tank drain, 19  
 Hourmeter, 11  
 How the machine works, 20

**I**

Indicators  
   Recovery tank full, 13  
   Scrub brush pressure, 15

**J**

Jack points, 73  
 Jacking, 73

**L**

Languages, Control panel message display, 12  
 Leveling the rear squeegee, 62  
 Levers  
   Parking brake, 17  
   Solution flow, 10  
 Lights, Operating lights switch, 16  
 Locking up side squeegees, 28  
 Lubrication, 50  
   Front wheel support bearing, 50  
   Propelling gearbox, 50  
   Rear squeegee casters, 52  
   Scrub head parallel arms, 51  
   Steering gear chain, 52  
   Steering universal joint, 50

**M**

Machine  
   Jacking, 73  
   Towing, 70  
   Transporting, 70  
 Machine components, 6  
 Machine dimensions, 77  
 Machine leaks, 21, 36  
 Machine tie down location, 72  
 Maintenance, 48–72  
   Intervals, 48  
   Recommended, 5

Maintenance chart, 48  
 Message display, Control panel, 12  
 Motors, Electric, 57, 76

**O**

On-off key switch, 16  
 Operating lights switch, 16  
 Operation, 5–54  
 Operation on inclines, 36  
 Operator Responsibility, 5  
 Operator seat, 19  
 Options, 37–45  
   ES™ switch, 14  
   Positive solution control drain, 19  
   Power wand, 41–45  
   Power wand switch, 17  
   Vacuum wand, 37–40

**P**

Parking brake, 17, 69  
 Pedal, Directional, 9  
 Pedals, Brake, 9  
 Positive solution control drain, 19  
 Post-operation checklist, 35  
 Power wand, 41–45  
 Power wand switch, 17  
 Pre-operation checklist, 21  
 Propelling circuit, 57  
 Propelling gearbox, 50  
 Pushing or towing the machine, 70

**R**

Rated incline and descent, 75  
 Rear squeegee, 62  
   Adjusting deflection, 64  
   Leveling, 62  
 Rear squeegee blades, 65  
 Rear squeegee casters, 52  
 Rear squeegee switch, 14  
 Recovery tank, 60  
   Drain hose, 19  
   Draining and cleaning, 31–33  
   Positive solution control drain, 19  
   Tank full indicator, 13

Recovery tank drain hose, 19  
Replacing rear squeegee blades, 65  
Replacing side squeegee blades, 67  
Replacing the scrub brush, 59  
Rotating rear squeegee blades, 65

**S**

## Safety

Labels, 4  
Precautions, 3

Scrub brushes, 58  
Brush pressure, 15  
Replacing, 59

Scrub head, 57–63  
Adjustments, 58  
Floor skirts, 58  
Gas spring, 58  
Parallel arms lubrication, 51

Scrub head adjustments, 58

Scrub head floor skirts, 58

Scrub head gas spring, 58

Scrub head parallel arms, 51

Scrub switch, 15

Scrubbing, 26  
Brush information, 25  
Double, 28  
General information, 25  
Stop, 30

Scrubbing brushes, 25

Scrubbing pads, 26

Self-diagnostics, 56

Service records, 36

Side squeegee adjustment, 65

Side squeegee blades, 66

Side Squeegees, Locking up, 28

Side squeegees  
Adjustment, 65  
Unlocking, 29

Skirts, Scrub head floor, 58

## Solution

Filling the tanks, 22–24  
Flow lever, 10  
System, 60  
Tank drain hose, 19

Solution flow lever, 10

Solution System, 60

Solution system, Solution valve, 60

Solution Tank, 61

## Solution tank

Drain hose, 19  
Draining and cleaning, 31–33  
Filling, 22–24  
Positive solution control drain, 19

Solution tank drain hose, 19

Solution valve, 60

## Specifications, 75–77

Braking system, 76  
Chargers, 76  
Electric motors, 76  
Machine capacities, 75  
Machine dimensions, 75  
Machine performance, 75  
Power type, 76  
Steering, 76  
Tires, 76

## Squeegee, 62–65

Blades, 65  
Deflection, 21, 35

## Squeegee blades, 65

Rear, 65  
Replacing or rotating rear, 65  
Replacing side, 67  
Side, 66

Starting the machine, 22

Static drag chain, 68

Steering, Specifications, 76

Steering gear chain, 52, 68

Steering universal joint, 50

Steering wheel, 10

Stop scrubbing, 30

Stop the machine, 34

Storage information, 74

## Switches

Edge scrub, 14  
ES™, 14  
On-off key, 16  
Operating lights, 16  
Power wand, 17  
Rear squeegee, 14  
Scrub, 15

Symbol definitions, 7

**T**

## Tanks

Recovery, 60

Solution, 61

Tie down location, 72

Tires, 69–70

Specifications, 76

Touch panel, Self-diagnostics, 56

Towing the machine, 70–71

Transporting the machine, 70–71

Troubleshooting, 46

**U**

Unlocking side squeegees, 29

**V**

Vacuum wand, 37–40

